

## Action full title:

**Universal, mobile-centric and opportunistic communications architecture**

## Action acronym:

**UMOBILE**



## Deliverable:

**D3.4 “UMOBILE ICN layer abstraction final specification”**

## Project Information:

<b>Project Full Title</b>	Universal, mobile-centric and opportunistic communications architecture
<b>Project Acronym</b>	UMOBILE
<b>Grant agreement number</b>	645124
<b>Call identifier</b>	H2020-ICT-2014-1
<b>Topic</b>	ICT-05-2014 Smart Networks and novel Internet Architectures
<b>Programme</b>	EU Framework Programme for Research and Innovation HORIZON 2020
<b>Project Coordinator</b>	Prof. Vassilis Tsaoussidis, Athena Research Center

## Deliverable Information:

<b>Deliverable Number-Title</b>	D3.4: UMOBILE architecture: high-level final specification
<b>WP Number</b>	WP3
<b>WP Leader</b>	DUTH
<b>Task Leader (s)</b>	UCL
<b>Authors</b>	<p><b>COPELABS:</b> Paulo Mendes</p> <p><b>ATHENA:</b> Sotiris Diamantopoulos, Christos-Alexandros Sarros, Vassilis Tsaoussidis</p> <p><b>UCL:</b> Ioannis Psaras, Sergi Rene</p> <p><b>UCAM:</b> Jon Crowcroft, Adisorn Lertsinsrubtavee, Carlos Molina-Jimenez</p> <p><b>TECNALIA:</b> Susana Perez Sanchez, Iñigo Sedano</p> <p><b>SENCEPTION:</b> Rute Sofia</p>



<b>Contact</b>	<a href="mailto:i.pсарas@ucl.ac.uk">i.pсарas@ucl.ac.uk</a> , <a href="mailto:s.rene@ucl.ac.uk">s.rene@ucl.ac.uk</a>
<b>Due date</b>	M30: 31/07/2017
<b>Actual date of submission</b>	31/07/2017

### Dissemination Level:

<b>PU</b>	Public	x
<b>CO</b>	Confidential, only for members of the consortium (including the Commission Services)	
<b>CI</b>	Classified, as referred to in Commission Decision 2001/844/EC	

### Document History:

Version	Date	Description
Version 0.1	03/07/17	First draft to the consortium for alignment with D3.3 and allocation of contributions
Version 0.2	19/07/17	Second draft to the consortium for alignment with D3.3 and allocation of contribution
Version 1.0	31/07/17	Final version to be submitted



# Table of Contents

List of Definitions.....	7
Executive Summary .....	11
1 Introduction .....	13
1.1 Background and motivation for a new architecture.....	14
1.2 Overview of the UMOBILE Architecture .....	16
2 UMOBILE architecture: Application/Service perspective.....	22
2.1 UMOBILE applicability .....	22
2.1.1 Micro-blogging.....	22
2.1.2 Emergency situation .....	22
2.1.3 Civil protection.....	23
2.1.4 Social routine improvement .....	23
2.2 Network features.....	23
2.2.1 Network scenarios .....	25
2.2.2 Communication models.....	28
2.2.3 Context services.....	29
2.2.4 Data services.....	30
3 UMOBILE architecture design.....	31
3.1 UMOBILE mechanisms.....	31
3.2 UMOBILE devices .....	36
4 UMOBILE modules .....	42
4.1 NDN plane.....	42
4.1.1 Naming.....	42
4.1.2 UMOBILE forwarding .....	45
4.2 NDN-based social-aware opportunistic routing framework (NDN-Opp).....	49
4.3 Contextual information manager .....	50
4.3.1 Usage context .....	53
4.3.2 Network context .....	53
4.4 INRPP - Flow control .....	54
4.5 Service migration platform .....	54
4.5.1 Service manager .....	58
4.5.2 Monitoring Manager.....	58



4.5.3	Decision engine.....	59
4.5.4	Service repository.....	59
4.5.5	Service execution.....	59
4.6	Connectivity manager.....	59
5	UMOBILE platform WP planning.....	61
6	Conclusion.....	63
	References.....	64

## List of Figures

Figure 1 - NDN Architecture [18].....	15
Figure 2 – UMOBILE architecture for mobile end-users .....	18
Figure 3 – UMOBILE ARCHITECTURE FOR NETWORK DEVICES: ROUTERS, GATEWAYS, SURROGATES AND HOTSPOTS .....	19
Figure 4 – WiFi hotspot network scenario .....	26
Figure 5 – Opportunistic network scenario.....	27
Figure 6 – Isolated areas network scenario .....	28
Figure 7 – POTENTIAL DEPLOYMENT SCENARIO OF THE UMOBILE PLATFORM .....	37
Figure 8 – UMOBILE end-users.....	38
Figure 9 – UMOBILE hotspot .....	39
Figure 10 – UMOBILE surrogate devices .....	39
Figure 11 – UMOBILE gateway.....	40
Figure 12 – UMOBILE router .....	40
Figure 13 - UMOBILE keyword-based naming scheme .....	44
Figure 14 – DTN-Forwarding .....	48
Figure 15- NDN-Opp illustration.....	50
Figure 16 - UMOBILE contextual information module.....	52
Figure 17 - Service-prefetching in emergency scenarios .....	58
Figure 18 – WP Planning .....	61



## List of tables

Table 1 - Correspondence between UMOBILE applications and requirements.....	24
Table 2 -- Correspondence between applications and UMOBILE mechanisms .....	31



## List of Definitions

Term	Meaning
DTN	Delay Tolerant Networking (DTN) is an emerging technology that supports interoperability of other networks by accommodating long disruptions and delays between and within those networks. DTN operates in a store-and-forward fashion where intermediate nodes can temporary keep the messages and opportunistically forward them to the next hop. This inherently deals with temporary disruptions and allows connecting nodes that would be disconnected in space at any point in time by exploiting time-space paths.
ICN	Information-Centric Networking (ICN) has emerged as a promising solution for the future Internet's architecture that aims to provide better support for efficient information delivery. The ICN approach uniquely identifies information by name at the network layer, deploys in-network caching architecture (store information at the network node) and supports multicast mechanisms. These key mechanisms facilitate the efficient and timely information (contents and services) delivery to the end-users.
Content	Content refers to a piece of digital information that is disseminated and consumed by end-user equipment.
Node	A wireless or wired capable device.
User	An entity (individual or collective) that is both a consumer and a relay of user services.
User Service	Refers to an application that provides a service to the user, either installed locally in the end-user device or provided from the network (central server or edge of the network). E.g. chat service or routeplanner service.
User application	Equivalent to user service.



Term	Meaning
User Interest	A parameter capable of providing a measure (cost) of the “attention” of a user towards a specific (piece of) information in a specific time instant. Particularly, users can cooperate and share their personal and individual interests that enable the social interactions and data sharing across multiple users.
User Requirement	User requirement corresponds to the specifications that users expect from the application.
Gateway	Gateway typically means an equipment installed at the edge of a network. It connects the local network to larger network or Internet. In addition, gateway also has a capability to store services and contents in its cache to subsequently provide local access communication.
Customer Premises	Customer Premises relate to residential households and enterprise market and are, as of today, controlled by the end-user.
User-centric	User-centric refers to a new paradigm leveraging user information at large to deliver novel content or services by users towards other users.
UMOBILE System	UMOBILE System refers to an open system that provides communication access to users through wired or wireless connectivity. This system exploits the benefit of local communication to minimize upstream and downstream traffic. The services or contents can be exchanged and stored in several devices such as gateways; user equipments; customer premises equipments such as WiFi Access Points in order to efficiently delivery the desired contents or services to end-users.
UMOBILE Architecture	A mobile-centric service-oriented architecture that efficiently delivers contents and services to the end-users. The UMOBILE architecture integrates the principles of Delay Tolerant Networking (DTN) and Information-Centric Networking (ICN).
User-equipment	User-equipment (UE) corresponds to a generic user terminal (for example smart phone or notebook). In terms of UE and for operating systems we consider mainly smartphones equipped with Android; notebooks with UNIX, Windows, Mac OS.





Term	Meaning
Social Trust	Trust which builds upon associations of nodes is based on the notion of shared interests; individual or collective expression of interests; affinities between end-users.
Application	Computer software design to perform a single or several specific tasks, e.g. a calendar and map services. In UMOBILE, context-aware applications are also considered.
Incentive	A factor (e.g., economic or sociological) that motivates a particular action or a preference for a specific choice.
Service	Service refers to a computational operation or application running on the network which can fulfil an end-user's request. The services can be hosted and computed in some specific nodes such as servers or gateways. Specifically, a service is normally provided for remuneration, at a distance, by electronic means and at the individual request of a recipient of services. For the purposes of this definition, " <i>at a distance</i> " means that the service is provided without the parties being simultaneously present; " <i>by electronic means</i> " means that the service is sent initially and received at its destination by means of electronic equipment for the processing (including digital compression) and storage of data, and entirely transmitted, conveyed and received by wire, by radio, by optical means or by other electromagnetic means; " <i>at the individual request of a recipient of services</i> " means that the service is provided through the transmission of data on individual request. Refer to D2.2 for further details.
Trust Association	A unidirectional social trust association between two different nodes.
UMOBILE gateway	Role (software functionality) which reflects an operational behaviour making a UMOBILE device capable of acting as a mediator between UMOBILE systems and non-UMOBILE systems – the "outside world".
UAV	Unmanned Aerial Vehicle, which is an aircraft with no pilot on board.
BSS	Basic Service Set is a set consisting of all the devices associated with a consumer or enterprise IEEE 802.11 wireless local area network (WLAN). The service set can be local, independent, extended or mesh. Service sets have an associated identifier, the Service Set Identifier (SSID), which



Term	Meaning
	consists of 32 octets that frequently contains a human readable identifier of the network.
CS	Content Store is responsible for holding information concerning the content carried by the current node.
PIT	Pending Interest Table is responsible for keeping up-to-date information concerning the data interests of the current node.
FIB	Forwarding Information Base is responsible for keeping track of the routes used to forward interests to the content.
SWR	Social Weight Repository is responsible for storing the list of interests the current node comes across (obtained upon encountering a peer).
SWM	Social Weight Measurer.
SWCDG	Social Weight and Carried Data Gatherer is responsible for obtaining the list of interests and social weights towards the encountered node.
NDN	Named Data Networking
EU	European Union



## Executive Summary

This document covers the UMOBILE architecture, as well as UMOBILE services that apply to scenarios detailed in D2.1 (End-user requirements report), for the specification of the UMOBILE architecture. This document incorporates the final and refined version of the UMOBILE architecture high-level specification that was initially defined in D3.3 (UMOBILE ICN layer abstraction initial specification) [1].

The goal of this document is to provide a high-level description of the overall specification of the UMOBILE architecture. Special attention is given to the necessary alignment with the Delay-Tolerant Networking (DTN) architecture [2], and the most relevant proposal for an Information-Centric Networking (ICN) architecture [3] that fits the identified UMOBILE system and network requirements. The specification provided here drives the development and implementation of the UMOBILE architecture, which is described in detail in deliverable D3.1 [4] and D3.2 [5] “UMOBILE architecture report 1 and 2” (e.g. core platform, API, protocols, software).

The starting point for this report are deliverables D2.1 “End-user requirements report” [6], D2.2 “Systems and network requirements report (initial version)” [7] and D2.3 “Systems and network requirements report (final version)” [8], which describes typical accessibility scenarios in different environments, namely, urban, remote and disaster areas, as well as requirements from the end-user (D2.1) and the network and system (D2.2 and D2.3) perspective, that the UMOBILE platform will support. The UMOBILE architecture specification, provided in this document, is complemented by the following deliverables:

- a) D3.2 [5] with a detailed specification of the UMOBILE architecture and the implementation of it.
- b) D4.1 [9] and D4.2 [10] with a detailed specification of the proposed flow control and rate-regulation scheme for UMOBILE.
- c) D4.3 [11] with a detailed specification of the proposed mobile name-based replication scheme aimed at improving certain services by using priorities.
- d) D4.4 [12] with a detailed specification of the different supported services and the QoS mechanisms in the UMOBILE project.
- e) D4.5 [13] with a detailed specification about sensing data collection and users’ behaviour inference.



The methodology used in this deliverable is as follows:

- a) Start from the applicability pictures identified in D2.1 and derive application services that must be implemented using the UMOBILE architecture.
- b) Identify the network services required for the services previously detailed.
- c) Describe the high-level design of UMOBILE architecture based on the overall assumptions and requirements described in D2.3, as well as the capabilities provided by the selected DTN and ICN architectures.
- d) Detail the different modules and describe the full specification of the UMOBILE ICN layer abstraction architecture, highlighting the components that need to be further described in D3.2, D4.1/D4.2, D4.3, D4.4 and D4.5



# 1 Introduction

The main objective of UMOBILE is to develop a mobile-centric, service-oriented architecture that efficiently delivers content and services to the end-users. UMOBILE decouples content and services from their origin locations, shifting the host-centric paradigm to a new paradigm, one that incorporates aspects from both information-centric and opportunistic networking with the ultimate purpose of delivering an architecture focused on: i) improving aspects of the existing infrastructure; ii) improving the social routine of Internet users via technology-mediated approaches; iii) extending the reach of services to areas with less or no infrastructure (e.g., remote areas, emergency situations).

UMOBILE also aims to push user services (e.g., web services, chat, etc.) as close as possible to the end-users. By pushing such services closer to the users, we can optimize, in a scalable way, aspects such as bandwidth utilization and resource management. We can also improve the service availability in challenged network environments. For example, users in some areas may suffer from intermittent and unstable Internet connectivity when they are trying to access the services.

To achieve this, the proposed UMOBILE architecture combines two emerging architecture and connectivity approaches: Information-Centric Networking (ICN) and Delay-Tolerant Networking (DTN). The aim is to build a novel architecture that defines a new service abstraction that brings together both information centric as well as delay tolerant networking principles into one single abstraction. We further integrate social trust computation into the architecture that will enable priority dissemination of information based on the notion of smart trust circles in opportunistic communication environments. Such an abstraction would enable network services to pervasively operate in any networking environment, independently of the underlying communication technology. Such abstraction also allows innovative application and services development, providing access to data independently of the level of end-to-end connectivity available.

In the scope of WP3 – System and architecture development – we previously defined a set of objectives aimed at specifying a full node architecture. These goals are:

- Design adequate delay-tolerant interfacing for underlying protocols that efficiently utilises the available resources for a challenged and opportunistic network environment.
- Provide service abstraction to applications by incorporating the notion of information-centric networking and named-data contents.
- Establish an overall network and system architecture.



- Implement an integrated prototype platform that can be used for the various deployment alternatives.

In this document we define the high-level design of this delay-tolerant and opportunistic data- and service-centric architecture that will provide the service abstraction to applications by using ICN principles. However, we point out that the last point of the objectives about implementation and integration are detailed in deliverables D3.1 and D3.2 of WP3 and WP5 (Integration and Validation).

## 1.1 Background and motivation for a new architecture

Most DTNs (i.e. RFC 5050 compliant [14]) rely on a host centric routing mechanism, passing bundles between nodes regardless of the data being exchanged. In contrast, Information-Centric Networks [3,15] allow the network to gain a better understanding of the data itself, enabling it to be easily cached and reused. Such support offers a huge potential in disrupted environments that rarely allow two hosts to reach each other. In [16], the authors identify similarities between ICN and DTN that seem to indicate that the integration of the two architectures is a logical progression, with the potential to combine the benefits of both. Importantly, we believe that the prominence of disconnectivity in daily situations (e.g. underground transport, poorly provisioned areas, during expensive roaming) means that any future Internet architectures must place a high priority on supporting delay tolerance. In addition, the new concept of fog/edge computing [17] is extremely interesting for new future Internet architectures to provide and assure the access to critical (and also non-critical) services in disrupted environments. Clearly, these examples motivate the need for an integrated architecture in opportunistic mobile networks.

In order to provide a new UMOBILE information-centric network architecture with delay-tolerant and opportunistic communications requirements, we will use the Named-Data Networking (NDN) [18] architecture as an initial approach. NDN will provide all the ICN abstractions required and we will extend it in order to provide new opportunistic, delay tolerant, social-aware and edge-computing features. We have chosen NDN instead of other ICN architectures (PURSUIT [19], DONA [20], Netinf [21], CURLING [22]) because NDN has been more widely accepted by the research community as a de facto standard for ICN. In the documents and Internet drafts of the IRTF Information-Centric Networking Research Group (ICNRG) [23] we can see that most of the community research efforts are focused on the NDN architecture.

NDN is an information-centric architecture that decouples content from network location. This decoupling is done by providing a new content hierarchical naming and content routing is based on these content identifiers, instead of location identifiers such as in IP. Routing is performed using similar algorithms to current IP infrastructure, utilising



longest prefix matching with hierarchical aggregation to ensure scalability, using a similar Forwarding Information Base (FIB) than IP. In NDN, a content request is issued by sending an Interest packet, which is routed through the network to the closest instance of the content (e.g., origin or surrogate server). Subsequently, the source responds with a data packet, which follows the reverse path back to the requester using “breadcrumbs” left in a Pending Interest Table (PIT) on each router. NDN also takes benefit of a Content Store (CS) where the data packets are cached in order to be resent when other users request the same packet that has been previously cached. This way, NDN can be more efficient allowing in-network routers to provide the content instead of the end-point source, and providing inherent support to multicast communications [24,25,26].

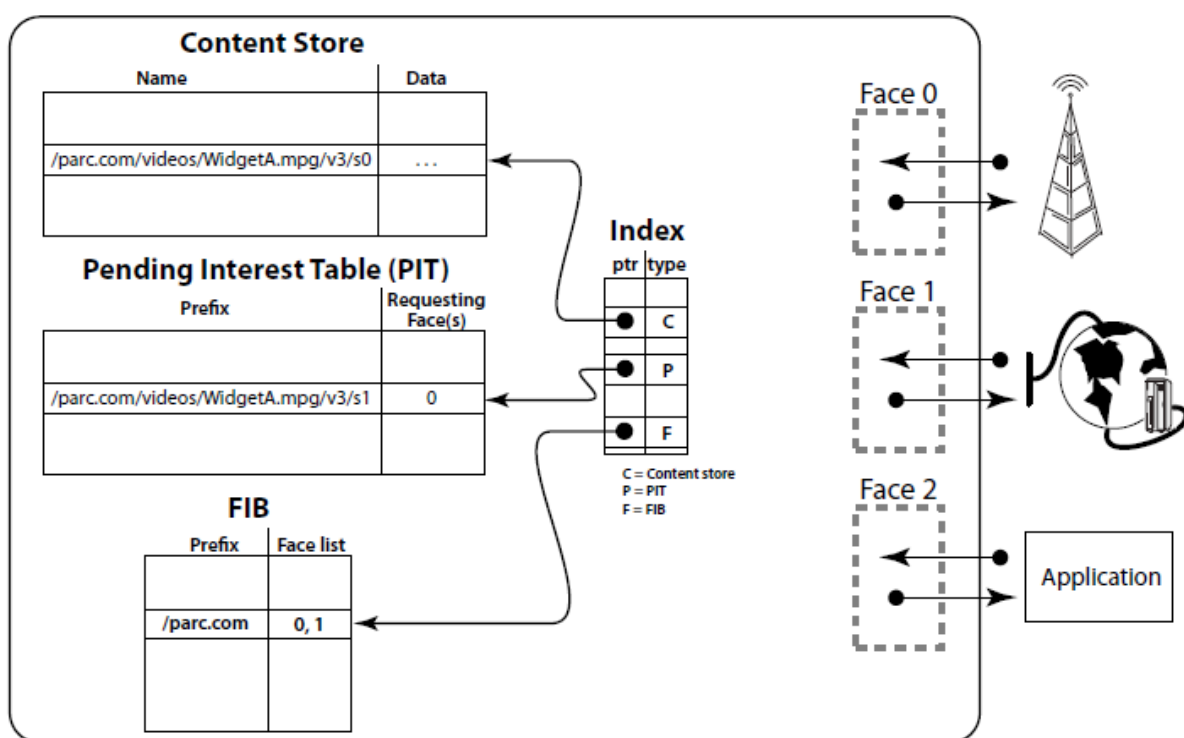

FIGURE 1 - NDN ARCHITECTURE [18]

The NDN-based architecture provides a set of features beneficial for mobile and wireless networks including among others:

- Native host multihoming: NDN does not bind a particular flow with a network interface. This provides a higher flexibility to use all the interfaces available to retrieve the data requested at the same time.
- Detachment of applications from location-oriented addresses: In NDN there is no necessity to force applications to take on location-oriented information. Instead, it detaches the application from such concerns. This allows the application to



abstractly publish or consume content, without the need to store (or even know) its own network-layer address [27].

- No connection-oriented sessions: In NDN there are no end-to-end sessions and all the communications are constrained at the network level. This removal of connection-oriented protocols allows the relocation of a host without the necessity of re-establishing a connection.
- Resilience through replication: Allowing local copies of the content to be retrieved, improves network performances and mitigates the effect of failures in mobile networks [28].

Despite the advantages of NDN in front of the IP architecture in terms of mobility, there is still some research challenges that need to be addressed in terms of mobility [29,15]. These research challenges are mainly the provider mobility, pairwise path routing (breadcrumb approach), request staleness or security and privacy. Moreover, there is no extensive research in the field of opportunistic wireless networks. Previous work on wireless networks has been focused on MANET [30], where machines are not constrained devices, or has been focused on wireless sensor networks and sink-centric data traffic [31] (i.e., sensor-to-sink or sink-to-sensor). In this project, we will go one step further and propose a universal, mobile-centric and opportunistic communications architecture that will exploit any communication opportunity between mobile devices to forward data towards receivers, exploring opportunistic communications and edge computing services.

## 1.2 Overview of the UMOBILE Architecture

In the UMOBILE project we propose a new data networking architecture that will integrate an ICN and a DTN approach. In order to provide delay-tolerant and opportunistic capabilities to the NDN architecture, in UMOBILE we will provide to NDN new forwarding mechanisms able to operate in opportunistic networks by using new logic faces, such as DTN faces, but also taking benefit of Device-to-Device (D2D) communications, enabling application sharing between users and opportunistic routing that will use social information to reach users without the participation of the network infrastructure.

UMOBILE needs to support various challenged scenarios such as aftermath of disasters or in rural/remote network deployments or networks with limited backhaul capacity. Such challenged environments pose several challenges such as increased latency, intermittent connectivity etc. To address these challenges, we also propose a resilient service migration module which utilizes advances in lightweight operating systems to push service instances right to the network edge, similar to the new fog edge computing





paradigm [17]. Instead of hosting the services in static location (fixed server), the service is considered as mobile content which can be accessed and executed anywhere within a local network. Inside a local network it utilizes a name-based routing/forwarding strategy, which brings in several benefits of ICN. Within the UMOBILE project, we utilise the NDN abstractions to carry out the name based routing/forwarding strategies. We also envision that our service migration platform also benefits from the underlying DTN to provide resilient access to services during periods of intermittent connectivity. In this challenged scenario, we also propose a new forwarding mechanism aimed at prioritising emergency information over less critical data, restricted to certain areas and time-space, in order to spread emergency information when no or partial infrastructure is available.

Throughout our studies on ICN the last few years, we have come to realise that with very few exceptions, there is very little work on information-centric service invocation. Naming and routing schemes have mainly focused on the delivery of static content. However, the emergence of edge-/fog-computing requires services (instead of merely static content) to be identified, resolved and executed at the edge of the network with minimal delays. In that direction of research, we have identified the need for an ICN keyword-based naming scheme aimed to help identify, resolve and execute available services in UMOBILE scenarios.

Last but not least, UMOBILE will provide to users new contextualisation services including recommendations, behaviour inference or affinity networking.

The UMOBILE architecture extends the NDN architecture [18] enabling opportunistic and social routing, opportunistic application sharing, contextualisation services and service migration at the end of the network. Since the network requirements of the list of UMOBILE-enabled devices are different (network vs end-user devices), the UMOBILE architecture consists of two parts, one for fixed network elements (e.g., routers, gateways, Base Stations, or WiFi Access Points) and a second one for end-user mobile devices (focusing mainly on the Android OS). We present the two parts of the UMOBILE architecture: one for the mobile end-users and another for the network devices. In Figure 2 we can observe the different components that the UMOBILE architecture will provide to extend NDN for mobile end-users. The functionalities of these components are respectively detailed in the Section 4. We can observe that network abstractions to the applications will be:

- **Keyword-based Mobile Application Sharing (KEBAPP):** KEBAPP enables access to the desired processed and non-personalised information through the concept of application sharing, effectively leveraging on a pool of application resources.



- **NDN-Opp:** UMOBILE provides new forwarding to perform opportunistic forwarding based on users' interests and their dynamic social behaviour, NDN-Opp includes some changes in relation to NDN in order to enable social-based information-centric routing over dynamic wireless networks.
- **Context services:** UMOBILE will provide contextualisation services to users, basically aimed at providing recommendations, behaviour inference or affinity networking.

Note that the figures are conceptual diagrams of the UMOBILE extensions required by NDN and the complete relational diagram providing all the relationships between modules with a full detail will be provided in D3.1.

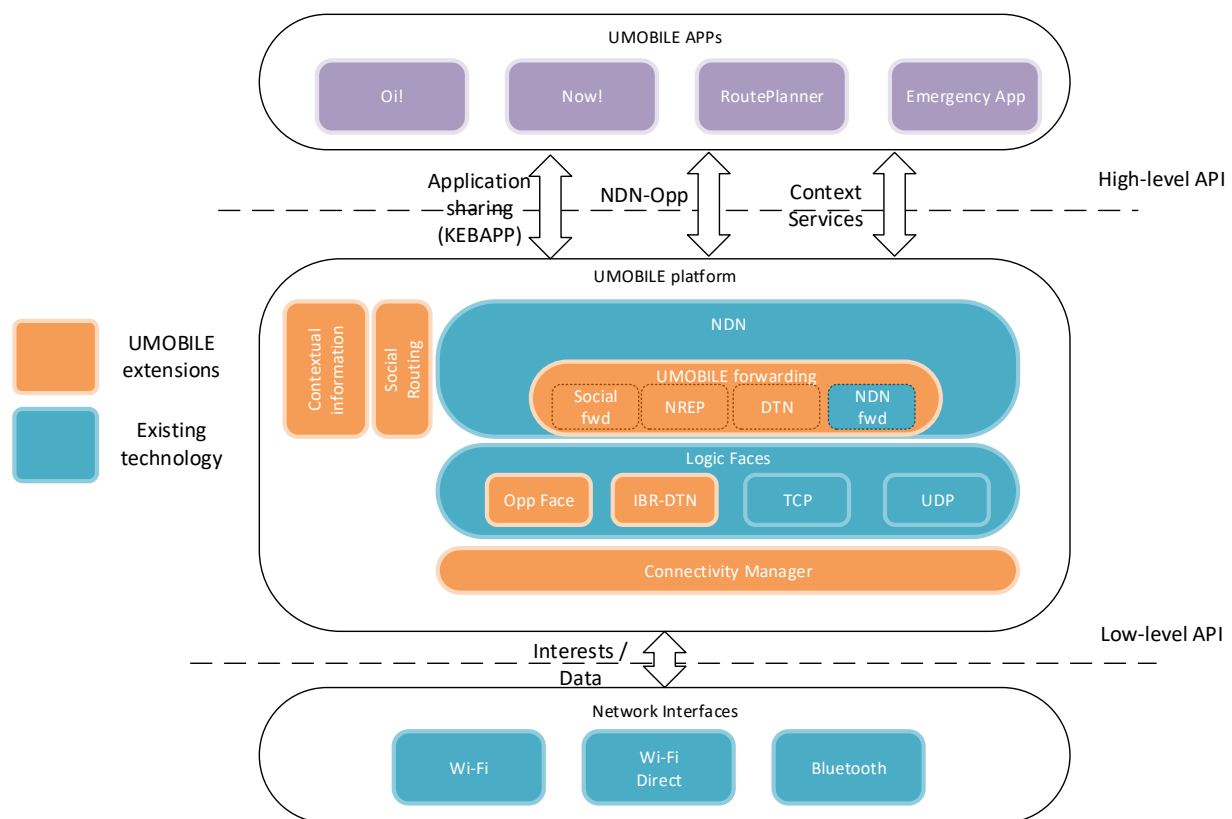

FIGURE 2 – UMOBILE ARCHITECTURE FOR MOBILE END-USERS

In Figure 3, we can observe the different components that the UMOBILE architecture will provide to extend NDN to the network devices such as routers, gateways, surrogates devices (e.g. UAVs) and hotspots (APs). The functionalities of these components are respectively also detailed in the Section 4. Targeting network elements at the fixed part of the network, this part of the UMOBILE Architecture does not include the components aimed at contextualisation and Device-to-Device (D2D) communications. Instead, this

part includes service migration modules and the INRPP protocol, as well as the Opportunistic Off-Path Content Discovery (O OCD). We can observe that network abstractions to the applications will be:

- **Service migration:** Service migration offers facilities to deploy services at the network work aiming at improving QoS (e.g., latency) as well as providing local availability of services where Internet connectivity is intermittent or broken down, UMOBILE includes a component to migrate services, bringing services from the core to the edge of the network (e.g., access points).
- **Keyword-based Mobile Application Sharing (KEBAPP):** KEBAPP enables access to the desired processed and non-personalised information through the concept of application sharing. In the case of the network devices, KEBAPP enables advertising and sharing applications instantiated in APs using service migration, making them available to the end-user devices.

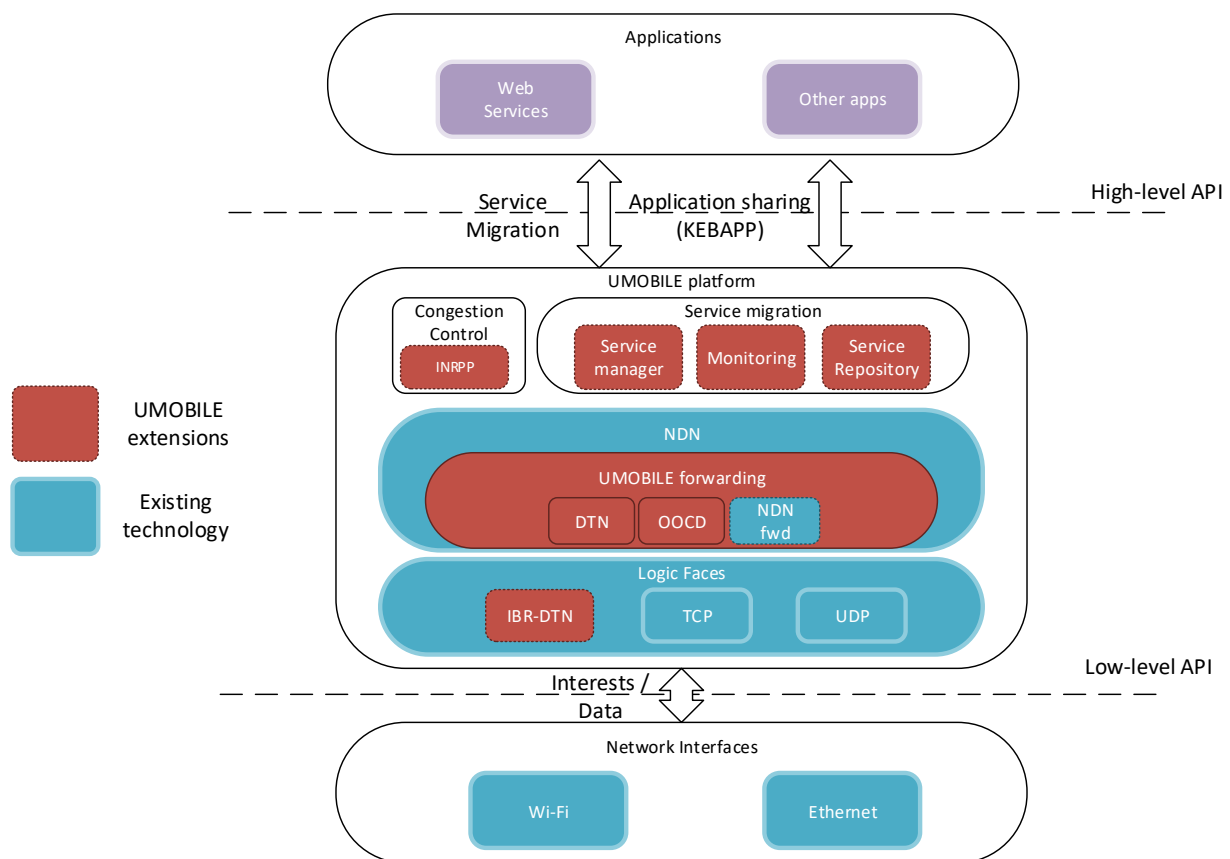

FIGURE 3 – UMOBILE ARCHITECTURE FOR NETWORK DEVICES: ROUTERS, GATEWAYS, SURROGATES AND HOTSPOTS

We briefly describe the functionality of each of the new components here, including both end-user and network devices, that will be further detailed in Section 4, and are necessary to provide the new services:

- **UMOBILE forwarding engine:** The basic objective of this module is to perform the best forwarding depending on the application requirements and the network context using the following forwarding characteristics.
  - **DTN forwarding:** This new forwarding mechanism is aimed at supporting delay-tolerant networking, by the introduction of NDN compatibility with the bundle protocol, extending opportunistic communications to DTN islands.
  - **NREP:** It introduces name-based push services with priorities for the disaster recovery case. In particular, messages spread through the network of mobile devices, based on their name, related priorities TTL and the geographic area where the message should be disseminated to.
  - **Social forwarding:** This new forwarding strategy used by NDN-Opp, aimed at supporting social opportunistic routing that will use the information of users' contacts to provide NDN communications where there is no infrastructure.
  - **OOCD:** The Opportunistic Off-Path Content Discovery (OOCD) introduces a new routing table in the NDN routing and forwarding engine. The target of this new routing table is to point Interests/Requests towards the edge of the network, only if Interests for the same content have been seen in the recent past. OOCD has been shown to not only improve significantly, but make possible communication in fragmented networks.
- **Social Routing Module:** This module is responsible of providing the necessary functions to calculate and populate routes based on social information and users' contacts.
- **Contextual Information:** This module is responsible of providing all the contextual information related with users' behaviour that will have interfaces with all the rest of the modules that require this information, such as the routing module.
- **Congestion control module (INRRP):** In-Network Resource Pooling Protocol (INRPP) INRPP is proposed as a radical way to improve network performance (in terms of file transfer time) in information centric networks, where routers are



equipped with caches. INRPP takes advantage of in-network caches to move content progressively in the network. INRPP is shown to bring advantage in case network fragmentation or severe congestion.

- **Service migration modules:** These modules support the service migration platform where the services (self-contained lightweight virtual machines) can be seamlessly migrated and cached across the network. The main component of service migration platform includes service manager, service repository and real time monitoring system.
- **New logic faces:** In order to provide delay-tolerant and opportunistic forwarding in UMOBILE we add two new faces, namely the NDN-Opp face, and the IBR-DTN face, necessary to use the bundle protocol in NDN, and NDN-Opp respectively.
- **Connectivity manager:** Used to discover users and networks enabling and facilitating access to the desired information. Shim layer between the logic faces and the network interfaces aimed at autoconfiguring logic faces depending on connections/disconnections and user/services discovered.

The set of different UMOBILE services aimed at extending NDN to provide the northbound services will be further described in Section 2.2.5 and will be detailed in deliverable D3.1.

The document is organized as follows:

- **Section 2** revisits the application/service perspective of UMOBILE, described in D2.1 and D2.2, and introduces more generic requirements that end up on the definition of the different UMOBILE services.
- **Section 3** introduces the architecture design of the UMOBILE platform including the list of different devices and UMOBILE services, and the network requirements that these services satisfy.
- **Section 4** details all the modules initially presented in the architecture.
- **Section 5** presents the development plan of the different UMOBILE services in the technical tasks and work packages of the UMOBILE project.
- **Section 6** concludes this deliverable.



## 2 UMOBILE architecture: Application/Service perspective

In this Section, we start by identifying (Section 2.1) the different applications exploited in UMOBILE, revisiting the four main applicability scenarios detailed in D2.1 [6]: *micro-blogging*, *emergency situation*, *civil protection* and *social routine improvement*. After that, we identify (Section 2.2) the network services that UMOBILE should provide in order to support the deployment of such applications in the mentioned scenarios, and in Section 3.2 will present the set of UMOBILE services aimed at extend NDN satisfying these requirements.

### 2.1 UMOBILE applicability

This section describes the applications used in each of the four applicability scenarios. Some of these applications will then be used to demonstrate the operation of the UMOBILE framework in selected use-cases.

#### 2.1.1 Micro-blogging

Users share interests in the form of tagged information where all UMOBILE users can benefit from the local information such as an interesting event, recommended place and social interaction activities.

- Recommendation (e.g. shopping, parking)
- Local News (e.g. art exhibitions; road accidents)
- Chat (e.g. music events)

#### 2.1.2 Emergency situation

UMOBILE system aims to assist users in disseminating emergency information directly via other end-user devices as well as via the UMOBILE hotspots and UAVs. Emergency applications can include data uploaded by users, or data collected for other devices and disseminated by UAVs, hotspots, etc.

- Instant messaging (send info to any authorities: fire);
- Emergency channel (e.g. info about safety places)
- Chat (family; school; community)



### 2.1.3 Civil protection

UMOBILE provides mechanisms that may assist responsible authorities in the case of challenged events. For instance, in the case of an earthquake, authorities in the affected areas can exploit data from different sources (satellite imagery, sensor-based, UAVs) to efficiently organize their efforts.

- Instant messaging (communication to home)
- Emergency channel (e.g. info about safety places)

### 2.1.4 Social routine improvement

UMOBILE capture users' personal data to improve their daily routine. The system shall perform simple and complex activity recognition, and learn with the users' habits to improve and prevent aspects such as social isolation. Examples of application of social routine improvement are:

- Recommendation concerning places; restaurants; lodging provided in a non-intrusive way, based on user and usage context.
- Instant messaging over intermittent connectivity to acquaintances (e.g. large event, without knowing where one's acquaintances are).

## 2.2 Network features

This section starts by identifying the set of network features that UMOBILE must support, derived from the scenarios and the application requirements described in the previous section, in order to allow the applications described to be used in the project applicability scenarios, as illustrated in



TABLE 1 - CORRESPONDENCE BETWEEN UMOBILE APPLICATIONS AND REQUIREMENTS

<b>Applications</b>	<b>Network scenario</b>	<b>Communication Model</b>	<b>Context Services</b>	<b>Data Services</b>
Recommendation (shopping, parking)	Hotspot Opportunistic	Pull	Recommendations	Dissemination Filtering
Local News (art exhibitions; road accidents)	Hotspot Opportunistic	Pull/Push	Affinity networks Recommendations	Dissemination Filtering
Chat	Hotspot Opportunistic	Pull	Affinity networks	Dissemination
Instant messaging (send info to any authorities: fire);	Opportunistic	Push	Behaviour inference	Dissemination
Emergency channel (e.g. info about safety places)	Isolated area Opportunistic	Push/Pull	Affinity networking	Dissemination Prioritisation

As we notice from Table 1 all applications require a data dissemination service (e.g. instant messaging), operating in Push or Pull mode.

The recommendation application used in the micro-blogging and social-routine improvement scenarios requires from the UMOBILE framework the capability to disseminate, filter data and predict users' preferences. Recommendations are pull-based communications. News and Chat applications also require a service able to identify affinity networks aimed at filter sources of news and chat members and push-based communications. Instant messaging requires push services in opportunistic communications and can use behaviour inference to improve the data dissemination of messages. To support an emergency channel, the UMOBILE framework also needs to provide user behaviour inference which is aimed at supporting automatic data subscription (e.g. alerts can be launched with more frequency depending on anxiety level; data dissemination can take into account the user social interaction). The different





applications must be able to operate in different network scenarios; these network scenarios depend on the connectivity level of the nodes.

The different applications require different functionalities related with the network scenarios, communications models, context services or data services. Depending on this, we will have to develop different UMOBILE services aimed at supporting all these features. In the table, we see that the applications can work on different network scenarios, detailed in Section 2.2.1. The applications may require different communications model (push/pull), detailed in Section 2.2.2. They may require as well different context services (Section 2.2.3) and/or different data services (Section 2.2.4). As a result of all these requirements we will work on different extensions to NDN (UMOBILE mechanisms -Section 3.1-) that may be present in each UMOBILE mobile node (e.g. smartphone), which communicate via public hotspots, isolated access points (e.g. UAV) or by using direct wireless communications (WiFi Direct).

### 2.2.1 Network scenarios

Deriving from the different scenarios detailed in D2.2, we extracted 3 different network context that UMOBILE architecture must cope with. These network contexts are detailed below:

- **WiFi hotspots w/ or w/o back haul internet connectivity**

The first case (Fig. 4) includes a network scenario where a set of users are connected to a WiFi hotspot that centralizes the communications inside a Basic Service Set (BSS). Each WiFi hotspot can be connected to the Internet, or it can be connected to another WiFi hotspot providing interconnectivity between different WiFi areas.



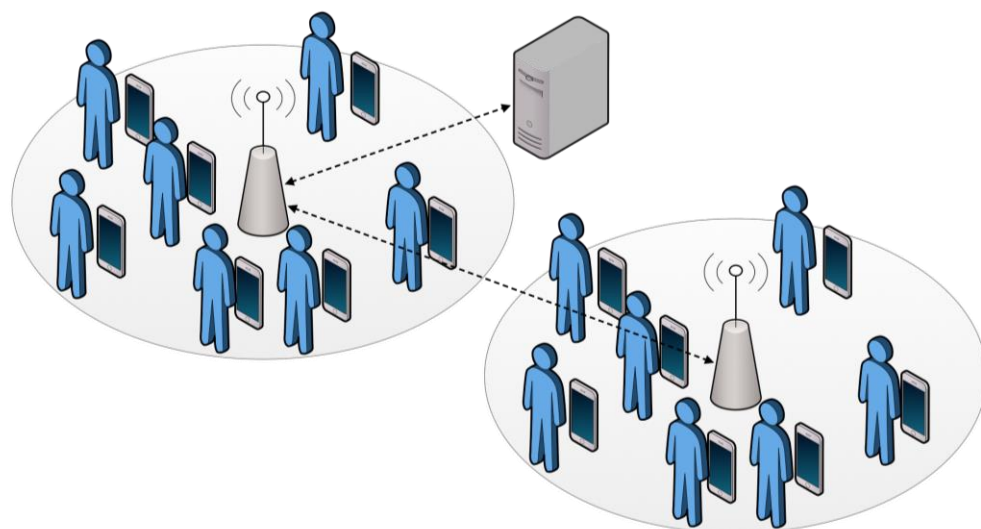
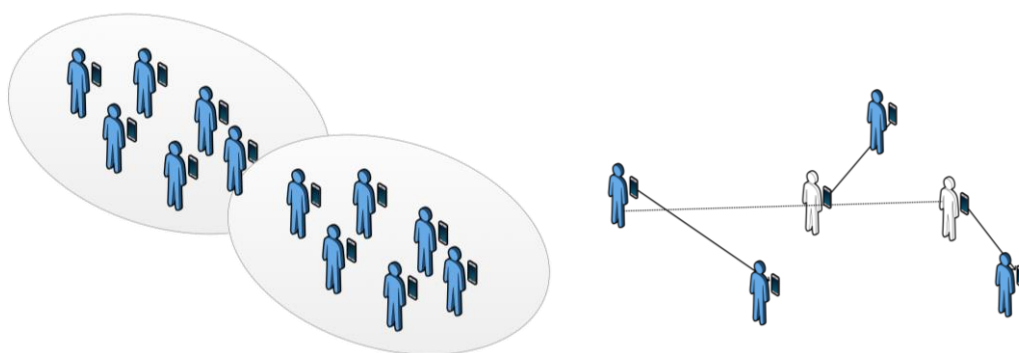

FIGURE 4 – WiFi HOTSPOT NETWORK SCENARIO

- **Opportunistic networks based on WiFi Direct**

In the second case, we focus on a network scenario where users must deal with opportunistic communication. That is, users do not have pervasive connection to the Internet, and they can have temporary encounters with other users, creating temporary connections between them. There are different cases of opportunistic contexts that we take into account in UMOBILE, as depicted in Figure 5:



a) USERS GROUPS

b) OPPORTUNISTIC USERS CONTACTS

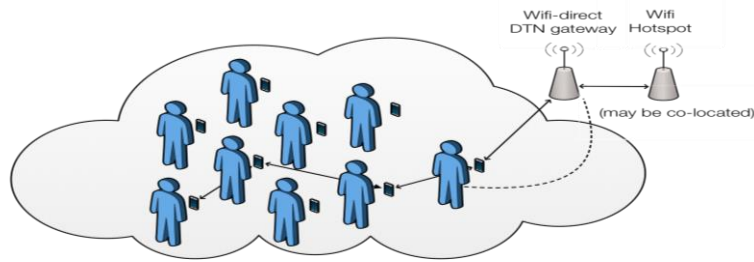

c) OPPORTUNISTIC NETWORK CONTEXT WITH GATEWAY

FIGURE 5 – OPPORTUNISTIC NETWORK SCENARIO

The first example (Fig. 5a) shows two formed groups of users connected between them using WiFi Direct connectivity. The second example (Fig. 5b) shows a set of different users that have sporadic contacts between them without forming a group between all the users. The third example (Fig. 5c) shows a set of users that can use opportunistic communications between them in order to reach a gateway, which may be co-located in the WiFi hotspot.

- **Poorly connected/isolated areas**

The last network context (Fig. 6) takes into account the scenario where a set of users are isolated from the network, but a mobile device interconnects them with the rest of the network using DTN capabilities. This mobile device acts as a data mule, and it can be a UAV device or any other vehicle, such as a public vehicle. Delay-tolerant forwarding can be beneficial in cases where data needs to be forwarded over vehicles, such as UAVs or emergency vehicles. This kind of connectivity can be deployed to provide communications in remote areas or in emergency cases. In addition, UMOBILE architecture also allows services to be run locally within the isolated areas in order to offload the communication over the intermittent link as well as enhance the QoS. This can be facilitated by the service migration module where the service at the mainframe can be migrated to the local access point by exploiting DTN capabilities. Nevertheless, the local access point may need to interact with the mainframe, for instance there is a new update for the operating service or local access point synchronises the usage data with the mainframe.

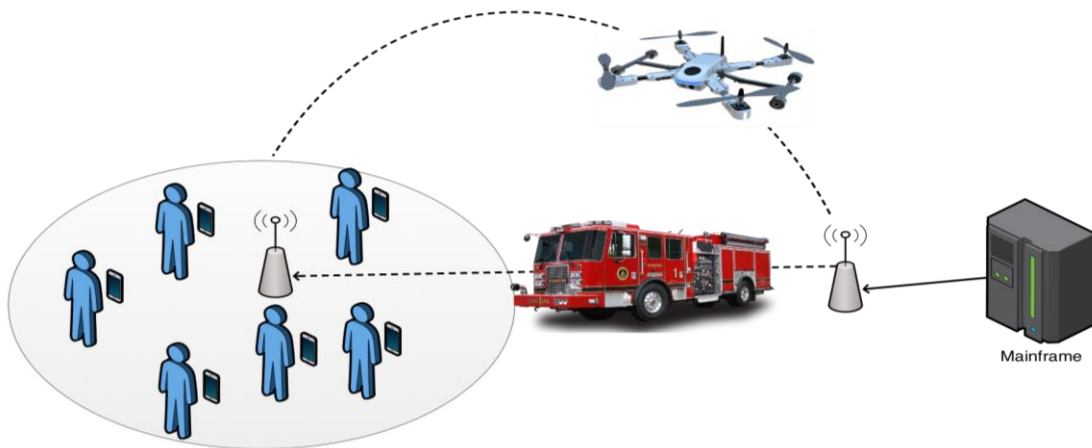

FIGURE 6 – ISOLATED AREAS NETWORK SCENARIO

It may happen that a vehicle is not present, so that the end-user mobile device is the only available in-network device to operate as a data mule. That is, the mobile phone is able to infer from its network context that conditions are suitable for DTN forwarding and act accordingly.

### 2.2.2 Communication models

As shown in Table 1 most of the identified applications require a data dissemination service operating pull mode (recommendations, news, chat). Aiming to support data dissemination in a pull mode, UMOBILE adopts the concept of ICN, which enforces the receiver-oriented chunk based transport and in-network caching. While in-network caching is beneficial under mobility, UMOBILE messaging applications (emergency, instant messages [32]) are push based. Therefore, the UMOBILE framework includes a push mode data communication as a fundamental unit and leverage both push and pull modes by application context.

Based on the scenario requirements, we define both a pull- and push-based communication model to be employed by the UMOBILE platform.

- Pull-based model:** This model is already supported by NDN. Clients requesting content initially generate and forward Interests. Content Providers (or any other node with the corresponding content cached) respond forwarding data towards the Interface they received the Interest following information in the Pending Interest Table (PIT).

- Push-based model:** With the current ICN model it is possible to support sender-oriented applications, e.g. [33,34,42,43], by adapting the pull model in order to have interests being registered in advance: e.g. I'm always interested in receiving emergency messages or messages from a pre-defined set of users. This approach has two major limitations: it requires the receiver to negotiate the data name in advance, which may not be suitable in unpredictable situations (e.g. an event); it may lead to a large overhead in UMOBILE scenarios, where nodes are mostly mobile and connectivity may be intermittent. In D3.3, we define several options to support a push-based model, and we decided to use Interests similarly to a publish/subscribe, where the server broadcast interests to clients that in turn issuing an interest back to the server in case they are interested in the new content released. This mechanism ensures perfect compatibility with NDN and does not have scalable issues such as using permanent interests in the Pending Interest Table (PIT) to push data to users without requiring an interest first. We adopted this model and named it as *Push-Publish data dissemination communication model*. This model is used in the service migration to migrate the service from the centralized service repository to the UMOBILE hotspot at the network edge.

### 2.2.3 Context services

As shown in Table 1 the identified applications require different context services, in order to improve and adapt the behaviour of the applications to the network context:

- Affinity networking:** Affinity networking takes benefit of the networking context in order to provide to users the control of the behaviour of the network directly by defining these affinity relationships and attributing specific policies to those relationships.
- Recommendations:** The recommendations service assists the users in finding and info quicker and easily, based on users' preferences.
- Behaviour inference:** No need to always access the Internet (good in large events); optimization based on wishes, needs and interests

The contextualization and behaviour inference module then integrates specific models. For instance, a UMOBILE mobile device may present a roaming preferences model, where the intent is to consider personal preferences in terms of visited wireless networks. Or, it may contain a model that relates with the need to share data opportunistically based on frequency or volume of wireless contacts. These models are defined by the user, based on specific parameters. The identified user's context is then used, together with the collected sensing data, to infer patterns of user behaviour.



## 2.2.4 Data services

As shown in Table 1 the identified applications require different data services in order to deliver and share data between UMOBILE nodes:

- Data prioritisation:** Some applications, such as emergency services, requires prioritisation over other data types with less criticality. Data dissemination should be optimised by prioritisation rules, integrated within the information message's name to favour spreading of the most important messages. The message replication will be limited by time and space, that is, within a certain geographic area and with specific life expectancy.
- Data dissemination:** This service is in charge of packet routing in a UMOBILE network. Based on the application and network context, different UMOBILE forwarding models are supported. This forwarding modes are detailed in Section 3.2. The selection of the best forwarding model to be used is done by the forwarding module taking into consideration both the application requirements and network context.
- Data filtering:** This service is in charge of gathering data about certain topics (e.g. recommendations) offering to users filtered data matching their interests taking into account information about physical surroundings and social context, behaviour inference and the detection of affinity networks.



### 3 UMOBILE architecture design

The envisioned UMOBILE architecture will efficiently operate in different network situations. Our intention is to extend the reach of ICN architectures to disconnected networks. Therefore, we intend to enhance the ICN architectural approach with an inherent tolerance to delays, disruptions and disconnections, inserting the DTN principles into the core of UMOBILE architecture. The great majority of the delay-tolerant approaches in the literature are based on the IP host-centric model, so when a node initiates a communication, its aim is to specifically reach another well-defined host. UMOBILE architecture is an information-centric delay-tolerant communication platform based on a node architecture that unifies the various underlying protocol choices within a single architectural framework. UMOBILE integrates DTN capabilities into a single ICN architecture on top of IP enabling diversity in supported networks. In UMOBILE, we do not provide a new Internet architecture, such as Named-Data Networking (NDN) [18]. In UMOBILE we focus on the mobile domain (as depicted in Figure 6), providing a new network architecture able to interact in social/opportunistic communications and based in ICN and DTN principles, with some extensions to the wired domain in order to bring the services closer to the users, improving the QoS. In the following sections, we detail the different devices that will support the UMOBILE framework, and the set of UMOBILE services that will be developed within the UMOBILE project, and integrated in the UMOBILE architecture.

#### 3.1 UMOBILE mechanisms

In Table 2 we can see a correspondence from the applications derived from the applicability scenarios described in D2.1, and the UMOBILE mechanisms developed to provide the network features required, and detailed in Section 2.2. Note that these applications are functionalities that are not going to be implemented in standalone applications since this is not the outcome of the project. In deliverables corresponding to WP5 “Overall platform integration and Validation” we provide more details about the applications developed within the project for demo purposes.

TABLE 2 - CORRESPONDENCE BETWEEN APPLICATIONS AND UMOBILE MECHANISMS

Applications	UMOBILE Mechanisms
Recommendation (shopping, parking)	Application sharing UMOBILE forwarding



	QoS
Local News (art exhibitions; road accidents)	Application sharing UMOBILE forwarding QoS
Chat	UMOBILE forwarding Contextualization services
Instant messaging (send info to any authorities: fire);	UMOBILE forwarding Contextualization services
Emergency channel (e.g. info about safety places)	UMOBILE forwarding Contextualization services QoS

In order to perform in all the aforementioned scenarios, being able to disseminate data and access services for all UMOBILE applicability scenarios and developing the different communication models and contextualization services, in UMOBILE project we are going to develop a set of mechanisms, provided to the applications, that will be integrated into a single architecture derived from NDN. The set of network mechanisms are described in Table 2, and we classified them per functionalities:

- Application sharing:** UMOBILE will provide a new application-centric information sharing framework named Keyword Based Mobile Application Sharing (KEBAPP) oriented to support and provide opportunistic computing to mobile devices (smartphones, tablets, etc.). Our approach targets scenarios where large numbers of mobile devices are co-located presenting the opportunity for localised collective information exchange, decoupled from Internet-access. In KEBAPP, we propose the creation and use of 802.11 broadcast domains for the support of particular applications i.e., KEBAPP-enabled hosts or APs advertise one or more Basic Service Set(s) (BSSs) for the support of one or more application(s). The creation of application-specific BSSs aims at enabling mobile devices to connect only when their counterparts support the same application and/or namespace. The advertising AP or host, through a WiFi Direct Group, acts as a mediator to





connect different users willing to share the same application in a single broadcast domain. In the case of APs, functionalities such as access control, association, encryption, etc., can be supported without imposing computation and/or battery overheads to mobile devices. In this context, KEBAPP employs application-centrism to facilitate/enable (i) the exchange of processed information, in contrast to merely static content, and (ii) the discovery and delivery of information partially matching user interests (data filtering).

- **UMOBILE forwarding:** The following set of forwarding mechanisms are going to be developed within the UMOBILE architecture:
  - **Social forwarding (NDN-Opp):** In order to perform opportunistic forwarding based on users' interests and their dynamic social behaviour, NDN-Opp includes some changes in relation to NDN in order to enable social-based information-centric routing over dynamic wireless networks. Based on the current specification of NDN, NDN-Opp provides a novel routing engine able of supporting opportunistic communications, and a forwarding engine that makes use of the existing Best Route forward strategy. NDN-Opp is the first attend to extend the NDN network towards opportunistic wireless networks, which: do not assume the existence of a communication path between any pair of nodes at any moment in time; exploit any communication opportunity between mobile devices to forward data towards receivers. To accommodate the intermittent nature of wireless connectivity, NDN-Opp introduces the concept of virtual faces. Changes to the current specification of NDN-Opp are expected in order to better align the proposed solution to the NDN framework, aiming to ensure an easy integration of UMOBILE networks in the existing NDN wired infrastructure.
  - **OOCD:** We will investigate a new scheme named Opportunistic Off-path content discovery (OOCD) the retrieval of content in disruptive, fragmented networks cases in NDN. To resolve and fetch content when the origin is not available due to fragmentation, we exploit content cached both in in-network caches and in end-users' devices. We introduce an extra Interest management routing table, which we call the "Satisfied Interest Table" (SIT) and which points to the direction of already satisfied Interests. This way, upon failure of links/nodes towards the content origin, the SIT table is redirecting Interests towards caches and end-users that have recently received the requested content. We believe that network management for



disruptive environments should take advantage of information-centricity, instead of focusing only on protocol-specific path recovery routing.

- **NREP:** In the immediate aftermath of a natural disaster, network infrastructure is likely to have suffered severe damages that challenge normal communications. In addition to that, traffic substantially increases as a result of people attempting to get in touch with friends, relatives or the rescue teams. To address such requirements of a challenged network, we are going to propose a mobile name-based replication system for disaster cases based on Name-based REplication priorities (NREP), where replication is optimised by prioritisation rules, integrated within the information message's name to favour spreading of the most important messages. The message replication will be limited by time and space, that is, within a certain geographic area and with specific life expectancy
- **DTN:** The main goal of UMOBILE project is the development of a networking architecture that supports both information centricity and delay-tolerance. We achieve that not only by providing delay tolerant communications natively using the NDN platform but also utilising DTN as an underlay and leveraging the IBR-DTN implementation<sup>1</sup>. This implementation provides opportunistic communications through DTN tunnelling when delay-tolerant transmission of data is deemed the most suitable alternative. Communication with the NDN overlay takes place through the newly-created DTN face and can be readily used by different NDN forwarding strategies. DTN forwarding extends the NDN functionality of remote prefix discovery and registration in order to gain awareness of isolated content, accessible only via a DTN island or a data mule. In this way a mobile node decides to invoke DTN forwarding through IBR-DTN face when appropriate, taking into consideration meaningful network information.
- **QoS:** In order to ensure QoS to end-users, we present three complementary mechanisms:
  - **Service migration platform:** We have implemented a service migration platform to help service providers deploy services (user services, i.e. applications) that are capable of complying with the QoS expected by the

---

<sup>1</sup> <https://github.com/ibrdtm/ibrdtm>



end-users. The modules that compose the service migration platform (described in Section 4.5) are flexible enough that can be used to deploy services in accordance with two different strategies: **service migration** and **service pre-fetching**.

- **Reactive migration:** Service migration is a reactive mechanism that a service provider can use to deploy instances of services as and where they are needed to meet the QoS expected from the services. It is a reactive mechanism in the sense that it is used at service delivery time to deploy instances in response to variations (between “vigorously running” and “showing signs of exhaustion”) of the status of the resources involved in the execution of instances. Examples of resources are the computers (Raspberry Pi) that we use in the UMOBILE project for realising the hotspots and the docker containers used for creating the instances of the services.
- **Proactive migration (pre-fetching):** Service pre-fetching is a proactive mechanism that a service provider can use to proactively deploy instances of services. It is a proactive mechanism in the sense that images of the services are cached in advance (for example at midnight) and as close as possible to where they will be subsequently used. The cached instances are not necessarily instantiated immediately after caching; enough for the service provider is to have them ready for instantiation when needed to meet the expected QoS requirements. As opposed to reactive migration, service pre-fetching has no notion of runtime resource exhaustion.

The service migration platform is meant to be used by service providers individually or in combination with other QoS mechanisms to help him or her satisfy the QoS requirements imposed on his services. Examples of QoS requirements are response time, availability, number of packets loss, etc. In this order, in UMOBILE project we use the service migration platform in combination with the DTN framework and INRPP to target specific QoS requirements.

- **INRPP:** Within the UMOBILE project, we aim to design and evaluate the In-Network Resource Pooling Protocol (INRPP), which pools bandwidth and in-network cache resources in a novel congestion control framework to reach global fairness and local stability. Taking profit of the hop-by-hop design and the caching capabilities inherent in the NDN networks, or adding caches (i.e., temporary storage) and breaking the end-to-end principle, we



argue that the demand factor can be tamed. Given this functionality of in-network storage, INRPP comprises three different modes of operation: push mode, store and detour mode or backpressure mode.

- **DTN:** The integration of the DTN and the NDN protocol provides to the UMOBILE architecture the feature to provide less-than-best-effort services, utilizing DTN as a mechanism to deliver services with low QoS requirements.
- **Contextualization services**
  - **PerSense Mobile Light:** In the context of UMOBILE, PerSense Mobile Light is a service that it is being developed to assist in performing network contextualization. Currently, PerSense Mobile Light captures information concerning a user's affinity network (contacts derived from WiFi Direct and Bluetooth) as well as concerning roaming habits, over time and space (WiFi). In a future version, PerSense Mobile Light shall collect data on user behavior, derived from additional sensors – the sociability forecasting module.

### 3.2 UMOBILE devices

In the following figure we show a summary of the UMOBILE network scenarios and the different devices that should support UMOBILE in order to provide all the services previously detailed:



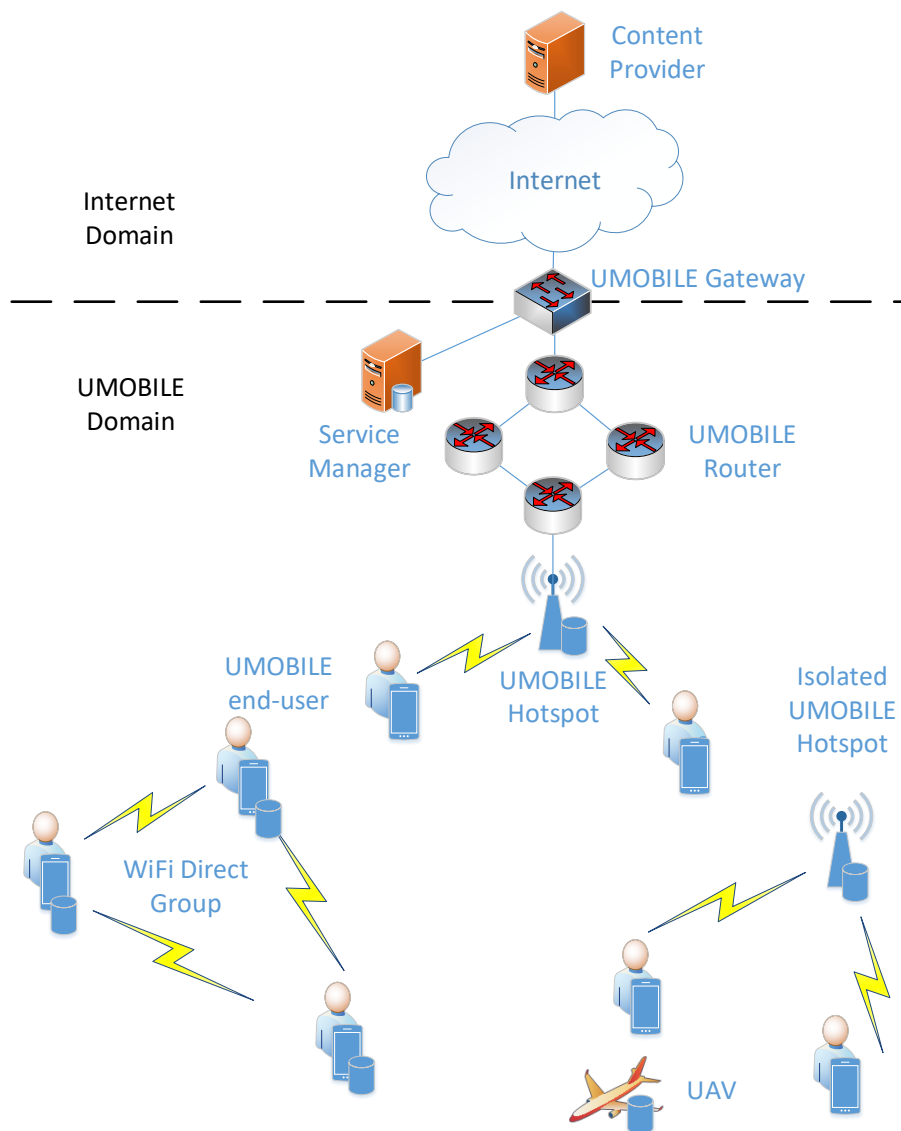

**FIGURE 7 – POTENTIAL DEPLOYMENT SCENARIO OF THE UMOBILE PLATFORM**

In order to provide opportunistic communications, a set of devices must support UMOBILE architecture:

- UMOBILE-enabled mobile devices:** (i.e., smartphone, tablet, wearable device, etc), used to send and receive participatory data (e.g. photos, short messages) as well as opportunistic data (e.g. atmospheric pressure, temperature, noise, people anxiety levels, roaming patterns).

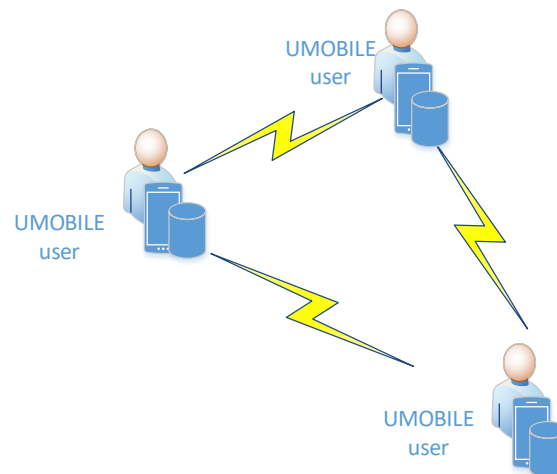

FIGURE 8 – UMOBILE END-USERS

**UMOBILE-enabled hotspots:** able to collect and relay relevant information (e.g., alert messages, instructions from emergency authorities), host some instantiated services (using the Service Migration function) or store collected data, check its validity and perform computational functions (e.g. data fusion) to increase the value of the information to the civil authorities.

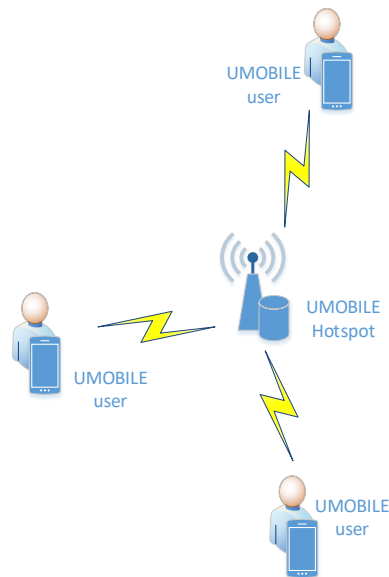

FIGURE 9 – UMOBILE HOTSPOT

- **UMOBILE-enabled surrogate devices:** or other vehicles able to collect and relay relevant information and connect two isolated areas.

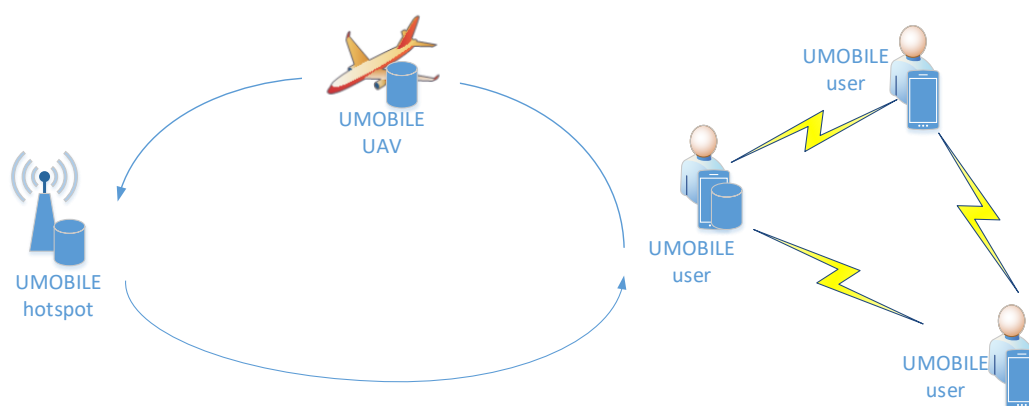

FIGURE 10 – UMOBILE SURROGATE DEVICES

- **UMOBILE-enabled gateway:** In order to provide connectivity between the UMOBILE network and the Internet (IP network), we devise a UMOBILE gateway

able to mediate between domains. The UMOBILE Gateway provides interconnectivity between the UMOBILE domain and the Internet domain. Such device can be employed by service and content providers to act as repositories, being able to store data received through the IP network and then to share it over the UMOBILE network (or vice-versa) upon request. In the framework of the UMOBILE project, focus is on service and content sharing over the UMOBILE network.

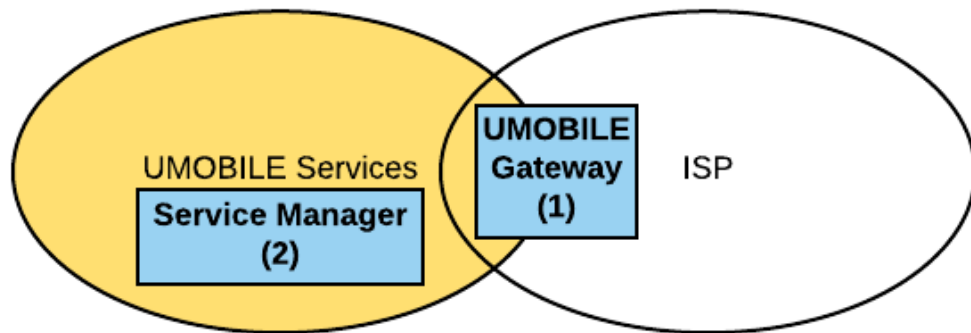

FIGURE 11 – UMOBILE GATEWAY

- UMOBILE-enabled routers:** In order to provide the Service migration service and the QoS mechanisms devised in this project, we require the UMOBILE-enabled routers. The difference between UMOBILE-enable routers and Internet routers is that UMOBILE-routers are supporting the UMOBILE protocols (based on NDN) and are compatible with the UMOBILE QoS mechanisms.

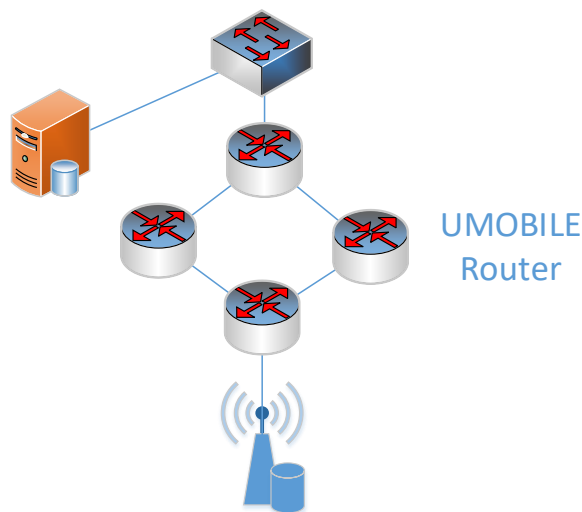

FIGURE 12 – UMOBILE ROUTER



The UMOBILE architecture must be able to work in the different areas of action detailed in D2.1 [6]. Therefore, depending on the situation, UMOBILE architecture must adapt to the environment to achieve the best performance. So, for example, it can use opportunistic networking in order to share the information between peers in a decentralized way, offloading communications from core network. On the other hand, in remote or disrupted emergency areas, UMOBILE may use DTN techniques to propagate the information from the source to the destination. To support such scenarios, the application servers which provides UMOBILE services could be able to migrate some services from the Internet and operate locally within the UMOBILE domain. For instance, the UMOBILE services could be executed at the public hotspots (as depicted in Figure 6) in order to mitigate the network latency regarding the challenged conditions (e.g., intermittent connectivity, limited bandwidth at the backhaul). This approach is the key benefit of service migration module which can improve the QoS for the end users.

In UMOBILE, content can be named using tags/keyword, aggregating content by similarities, simplifying the naming scalability issues in the NDN approach and the search of content in the UMOBILE network. This approach is further detailed in Section 4.1.1. UMOBILE architecture must support different network technologies. UMOBILE architecture must support the ability to communicate with a wide variety of underlying protocols, implementing convergence layers for several underlying technologies, like 802.11, cellular (3G/4G), satellite, Bluetooth communication, etc. The technology used by UMOBILE for opportunistic communications will be WiFi Direct, based on 802.11 technology.



## 4 UMOBILE modules

In this Section, we describe the different modules that are part of the UMOBILE architecture, shown in Figure 2 and 3 in Section 1.

### 4.1 NDN plane

The UMOBILE architecture is based on the current NDN architecture and will reuse most of its components, adding new ones to provide the features and network requirements previously specified. These NDN components that will be reused by the UMOBILE platform are: communications based on interests, content store, Pending Interest Table (PIT), Forward Information Base (FIB), caching policies and forwarding strategies. The naming used in NDN will be modified in order to provide more flexibility, required in opportunistic communications where the lack of infrastructure requires more flexibility in terms of the content that can be found in the different nodes.

#### 4.1.1 Naming

The discovery and invocation of services/applications in the networking vicinity of a user build on a naming scheme that enables the fine-grained description of the desired information.

To this end, UMOBILE builds on the observation that mobile computing is largely application-centric, in the sense that users tend to access information using purpose-built applications. Application-centricity presents a series of important characteristics:

- Applications inherently support the structuring of the name space within their semantic context. In turn, instances of the same (or similar) application can share the same name space in describing the related information e.g., categories in a news application.
- Applications are inherently used for computation, enabling the (lightweight) processing of content/information e.g., searching, sorting data or computing a route.

Taking these features into account, UMOBILE names are composed of two main parts (see Fig. 12):

- **Fixed Hierarchical Part.** It follows the hierarchical naming scheme of NDN and its purpose is to guarantee compatibility between instances of the same or different services/applications. Application developers can define their own hierarchical name spaces, enabling the communication between different instances of the application e.g., */NewsApp/politics/international*. Further enabling communication between different applications goes through naming conventions

that can build on the currently followed categorization of applications in popular application markets e.g., extending “/Travel & Local/” in Android App Market, to “/Travel & Local/Car Rentals”.

Moreover, application developers can also define suffixes corresponding to specific functionalities within their applications (in addition to static content), enabling this way the sharing of computation e.g., the name */MyTravelAdvisor/Top10Restaurants* is used to identify the list of the top-10 restaurants in a certain area. The Hashtag part of the name, described below, is used to define the sorting criteria and the selected area.

According to our initial design this part of the name will have to be an exact match in order for the request to be formed. That said, however, it will be difficult for users to imagine the different parts of the name that the application developer has defined.

- **Hashtags.** The second part of the name comprises of hashtag-like keywords, which the application developer can add to the application. The exact semantics of the hashtags depending on whether the fixed hierarchical part of the name corresponds to static content or an application function(ality). In the former case, these keywords are used to semantically annotate the static content. This feature enables the partial matching of requests with available cache or routing/forwarding entries i.e., given an exact match in the fixed hierarchical part of the name, hashtags can be used to support approximate matching enabling the search of information in other devices.

When the fixed part of the name identifies a certain application function(ality), the hashtag part of the name enables the passing of adequate parameters. In the aforementioned example of the *MyTravelAdvisor* application, the complete name included in a user request can have the fixed hierarchical part */MyTravelAdvisor/Top10Restaurants* and the hashtags *\#userrating*, *\#areaY*, *\#indian* indicating that the user is interested in the top-10 of the indian restaurants in areaY, according to users’ ratings. The submission of hashtag values is guided by the application GUI and can include both predefined value ranges e.g., the sorting criteria for the top-10 restaurants, and free text fields e.g., a user requests */MyNewsApp/politics/search #Syria #negotiations* to use the search function of *MyNewsApp* in order to find anything related to negotiations for Syria. In another example, an application following the naming conventions of the app market place issues a request for the name */news/politics/search #Syria #negotiations*, which can match any application supporting a *search* function.



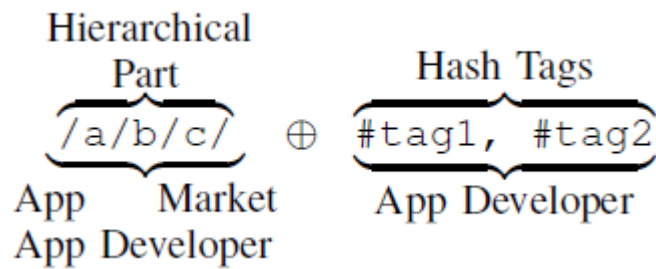

FIGURE 13 - UMOBILE KEYWORD-BASED NAMING SCHEME

We believe that the naming-scheme presented above can be rather efficient in narrowing down the range of the services to be executed and therefore, the results that will be returned to the user.

Below we include example naming schemes for the proposed applications in Section 2.2:

- Recommendations:

A user is walking on Oxford Street in London and wants to buy men's clothes that are on sale.

Fixed Hierarchical Part:        /ShoppingApp/Clothes/Men

Hashtags:                        \#London \#OxfordStreet \#Sales

- Chat:

A user would like to participate in a chat with other parents of the same class of their children school, in case of emergency.

Fixed Hierarchical Part:        / EmergencyApp /Chat

Hashtags:                        \#SchoolName \#3rdGrade

- Instant messaging:

In this scenario, a user wants to establish communications with any fire station in central London to provide information about a fire.

Fixed Hierarchical Part:        / EmergencyApp /InstantMessaging

Hashtags:                        \#CentralLondon \#FireStation

- Emergency channel:

In this scenario, a user knows that a fire has broken out within the university campus in Xanthi and is looking for an evacuation plan.

Fixed Hierarchical Part:     /EmergencyApp/Xanthi/Fire

Hashtags:                     \#UniversityCampus \#EvacuationPlan

- Local News:

A user is willing to find gigs and live music in central London.

Fixed Hierarchical Part:     /NewsApp/arts/exhibitions

Hashtags:                     \#CentralLondon \#Music \#Today

#### 4.1.2 UMOBILE forwarding

In order to provide more features and opportunistic capabilities to the NDN architecture, in UMOBILE we need to add different strategies that the ones provided by NDN, that are *best route*, *broadcast*, *client control* and *NCC* [35].

The core of our information-centric communication model lies in the usage of Interests issued by clients (pull-based model) or content providers (push-based model). In order for these Interests to be successfully delivered, a decision must be made on whether, when and to whom an Interest should be forwarded. Given the diverse application requirements, along with the varying networking conditions that may span from continuous high-speed connectivity to intermittent disruptive communications, a collection of different forwarding strategies needs to be supported by the UMOBILE architecture.

In particular, we envision a per-namespace selection of the forwarding strategy and we divide the forwarding strategies that UMOBILE will support into four main categories, based on their goal and the parameters used:

- Typical NDN forwarding
- DTN
- OOC
- NREP
- Social forwarding



All basic forwarding decisions are made in the UMOBILE forwarding module, a central part of the UMOBILE platform. In particular, the forwarding module is responsible for selecting the optimal way to forward packets, based on the following inputs:

- Usage context (e.g. packet priority, application delay-tolerance, user delay-tolerance, social information).
- Network context (e.g. WiFi Direct connectivity, UAV connectivity).

In the following, we describe the forwarding strategies that the UMOBILE platform will support.

### Typical NDN

Interoperability between UMOBILE and NDN necessitates that the typical NDN forwarding strategies are also supported. In particular, UMOBILE will include the following NDN strategies:

- Best Route: This strategy forwards Interests to the interface with lowest routing cost.
- Broadcast: The broadcast strategy forwards Interests to all eligible interfaces.
- Client Control: This strategy allows a local application to choose the outgoing face of each Interest.
- Ncc[35]: This strategy, initially implemented for CCNx, is capable of employing multiple Interfaces to forward Interests, based on a prediction function.

In the framework of the UMOBILE project, we devise a new set of forwarding strategies as a means to support scenarios involving long end-to-end delays but short hop-by-hop links. Typical use cases under this category are transmissions involving data ferries (e.g., UAVs). More specifically, we provide delay-tolerant characteristics to the strategies described in 4.3.1.2.1 by extending specific timers and modifying Interest and Data packet pipelines to exploit Interfaces that become available in a future moment.

### DTN

This forwarding strategy effectively connects NDN nodes over DTN links. Typical use cases for this type of connectivity are opportunistic networks (e.g., festival or emergency communications). Design-wise, we depart from most of the existing work (e.g.,[36]) which develops mechanisms for delay-/disruption-tolerant data transfers in ICN from scratch. Instead, we embrace a layered design leveraging the well-mature DTN mechanisms for data ferrying and routing in challenging environments, when such need arises. Towards this end, we enhance the NDN architecture with a new DTN face, communicating with an underlying DTN implementation.



Implementation-wise, a DTN face is created to interconnect the NDN forwarding daemon with the IBR-DTN<sup>2</sup> platform. This DTN face can be used by any route rule on a UMOBILE node, to note the next DTN-enabled UMOBILE node as the next hop for a given Interest prefix. Either proactively or reactively, depending on the forwarding strategy employed, NDN Interest and Data packets are passed to the IBR-DTN platform via the DTN face, and a DTN tunnel is formed between the two nodes. That way, the NDN overlay is responsible for caching and NDN forwarding between NDN nodes, whereas the DTN underlay is responsible for i) routing packets inside the DTN island employing DTN-specific routing algorithms, ii) providing reliability over lossy communication channels (e.g., in the case of opportunistic networks), and iii) enabling the utilisation of communication links that are not available at the time of transmission but are scheduled to become available in the future (e.g., in the case of data muling through UAVs or vehicles). It should be noted that by following this design approach we abstract the communication details from NDN, since they are handled transparently by the DTN layer. As a result, different DTN implementations can be integrated, depending on the deployment requirements, allowing for a greater degree of flexibility in the UMOBILE platform.

The DTN forwarding module includes the functionality of discovering available content (registered prefixes) in the DTN nodes so that an NDN node at the edge of a DTN island for instance, is able to create a DTN face for a remote device (and register a prefix to that face), although having neither previously encountered that node, nor received associated prefix beforehand.

In Figure 14, we can observe the two different modes that DTN forwarding allows. The DTN forwarding engine can be employed either proactively or reactively by the application. Proactively employing DTN requires either the use of the client-control forwarding strategy by the consumer application (so that next hops forward the Interest through the DTN face), or the use of specific hashtags that notify all nodes across the route that a DTN-related strategy should be selected for the forwarding of the former's data. The first option decouples the DTN face from any particular naming scheme, while the second is tied to hashtags designated for delay-tolerant data. Reactive DTN employment leverages the reception of congestion-related messages from the network.

---

<sup>2</sup> <https://trac.ibr.cs.tu-bs.de/project-cm-2012-ibrdsn/wiki/docs>



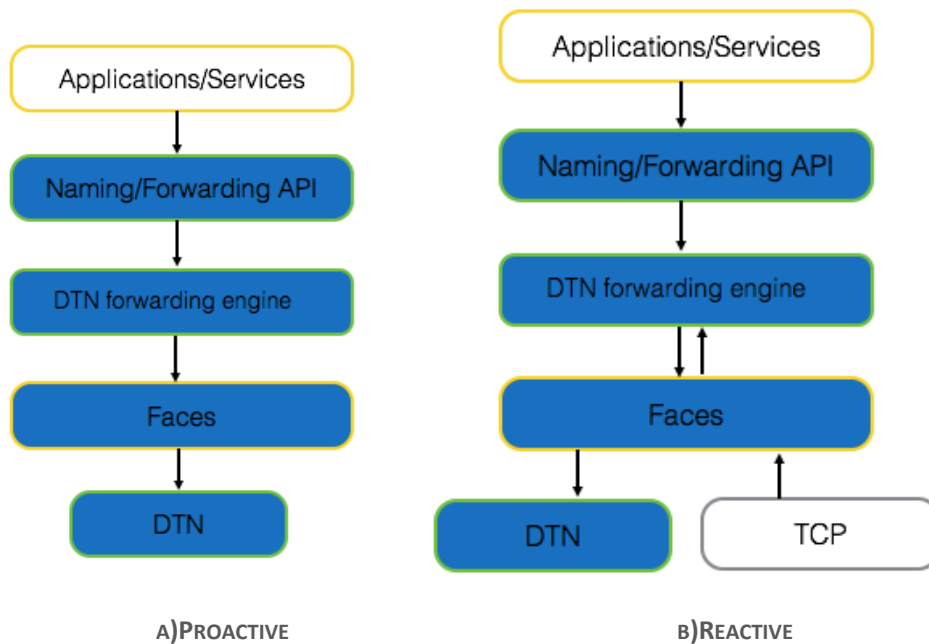

FIGURE 14 – DTN-FORWARDING

## OOCD

This forwarding strategy is aimed at forwarding the content not only from the source of the content, but also using the NDN extension the Opportunistic Off-Path Content Discovery (OOCD) provides, to discover other users that recently downloaded the same content, and are willing to offer the same to content to the requesting user, in case that network fragmentation does not allow to retrieve the content from the source of it.

## NREP

NREP forwarding strategy is aimed at support the Name-based REplication priorities (NREP) approach, where replication is optimised by prioritisation rules, integrated within the information message’s name to favour spreading of the most important messages. The message replication will be limited by time and space, that is, within a certain geographic area and with specific life expectancy, enabling the emergency services prioritisation in disaster cases.

## Social forwarding

NDN-Opp, *the NDN framework for Opportunistic Networks* included in UMOBILE that enables social-based information-centric routing over dynamic and opportunistic wireless networks, will require a new forwarder able to support this kind of opportunistic communications. NDN-Opp functionalities are explained in the next section.

Note that in this first version of the high-level specification of the UMOBILE architecture, we have different forwarding strategies for most of the different UMOBILE services.



However, in WP5 we will focus our efforts in the integration part, and it is possible that some forwarding functionalities could be integrated into the same forwarding strategy. Therefore, it is possible that the list of required forwarding strategies could change in the final version of the high-level architecture specification in D3.4, to be submitted in M30.

## 4.2 NDN-based social-aware opportunistic routing framework (NDN-Opp)

Routing in UMOBILE primarily targets opportunistic wireless environments. Thus, in the context of our architecture we have developed a relevant routing module, NDN framework for Opportunistic Networks (NDN-Opp), that is able of exploiting wireless communication opportunities. NDN-Opp provides an Android implementation of NDN for opportunistic networks.

NDN-Opp handles the dynamics of opportunistic networks by forwarding interest packets towards neighbors with high probability to meet nodes carrying the interested data. To be compatibility with NDN, NDN-Opp uses the NDN best route forwarding strategy to deliver interest packets, and the NDN “breadcrumb” approach to deliver data packets based on the information stored on the PIT.

NDN-Opp implements the NDN pull communication model, supporting data sharing applications, such as Now@, and a push communication model used by interactive applications, such as the short message application, Oi! [37]. To handle intermittent connectivity, NDN-Opp includes the concept of Opportunistic faces (Opp Face), currently implemented based on Wi-Fi direct. An Opp Face can be in two states (ON and OFF), and is named after an identified neighbor. Since forwarded packets may not be immediately dispatched, Opp Faces implement two queues: i) Interest Queue (IQ), storing Interest packets to be sent; ii) Data Queue (DQ) storing pointers to the Data block (in the Content Store) to be send.

As shown in Figure 15a, the operation of an NDN-Opp node is similar to the NDN operation, as the node state is changed by the arrival of Interest or Data packets. Figure 15a also shows that contrary to the faces used by NDN, Opp Faces create an indirection: NDN operation finishes with a packet being send; NDN-Opp operation ends with a packet being stored in an Opp Face. Packets are transmitted by serving interest and data queues when Opp Faces get up.

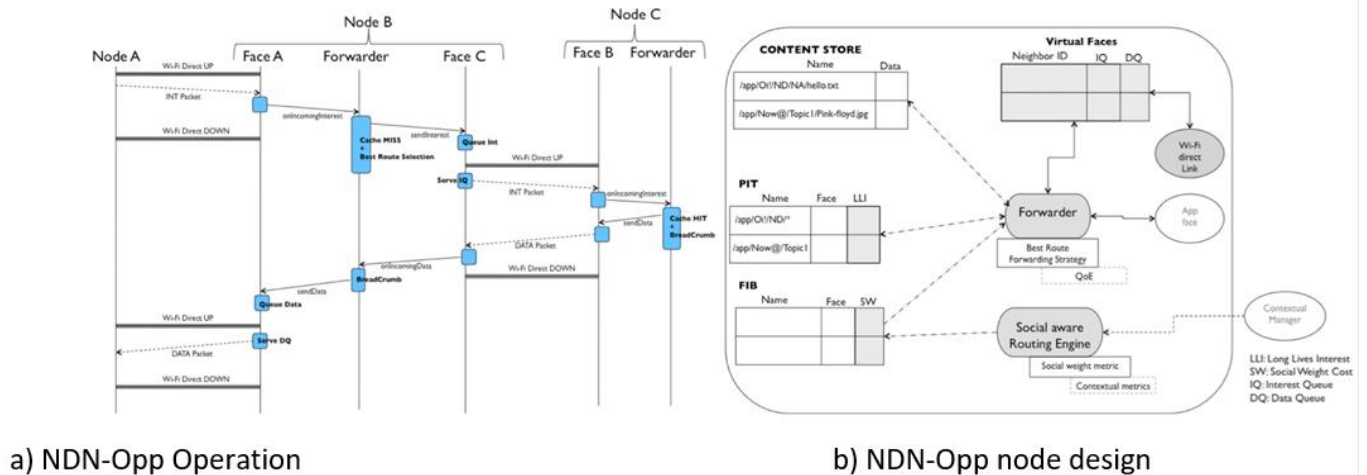

FIGURE 15- NDN-OPP ILLUSTRATION

Figure 15b shows NDN-OPP design based on a novel forwarder and routing engine. Upon reception of an Interest packet, the NDN state machine is used, but the PIT stores also information related to the duration of the Interest (Long Lived Interests - LLI). Interest packets are forwarded based on the NDN best route forwarding strategy, being the cost of name prefixes (stored in the FIB) related to social weights computed by a social-aware routing module. Data packets are forwarded following the normal NDN operation.

The social-aware routing engine computes the costs of using *Opp Faces* to reach data related to specific name prefixes. The proposed routing engine can run any type of social-aware opportunistic routing algorithm: NDN-OPP currently makes use of the Time-Evolving Contact Duration algorithm (TECD) used by routing protocols such as dLife [38] and SCORP [39]: computing routing information based on social interactions has great potential as less volatile proximity graphs are created.

### 4.3 Contextual information manager

The context plane takes care of the collection, resolution, and storage of the context. The context can be related to the usage and network context.

Context-awareness is based on gathering (capturing) data available via the wireless medium about physical surroundings as well as about social context. The user is seen as a carrier of a mobile object. Its context is captured non-intrusively via local connectivity (external) as well as on device usage (internal). By non-intrusive it is meant that this service takes advantage of the natural networking footprint that is overhead by devices, be it via Wi-Fi, Bluetooth, as well as any other means (e.g. LTE Direct). Our current



implementation efforts are focused on short-range wireless in the form of Wi-Fi and Wi-Fi Direct, as well as Bluetooth.

The contextual agent (named Contextual Manager, CM) can therefore be seen as an end-user background service, that seamlessly captures wireless data to characterize a device's affinity network (roaming patterns and peers over time and space) as well as the device's usage habits and interests (internal device information). This data capture is performed directly via this service via the regular MAC Layer operation (Wi-Fi Direct, Bluetooth) as well as via native applications for which the user configures interests or other type of personal indicator preferences. For instance, an application can request a one-time configuration of categories of interests such as music, food, etc. Such meta-data is passed to the contextual manager, associated to the device id. Metrics derived from such contextualization are then passed, upon demand or periodically, to other planes, such as the routing plane. Hence, the CM interacts with the routing plane via the provisioning of specific utility functions that provide indicators (e.g. routing costs and/or routing utility functions) of the social behaviour of users to assist in a more efficient data dissemination.

The operation of this module starts by having sensing data begin collected by mobile devices. As illustrated in Fig. 16 where we represent the current status of development of the contextual manager. A full specification of this module shall be provided in Deliverable D4.5. In the figure, 1 and 2 are interfaces to the social routing module, 3 is an interface for NREP to provide usage and network context, and 4 is an interface to the applications.



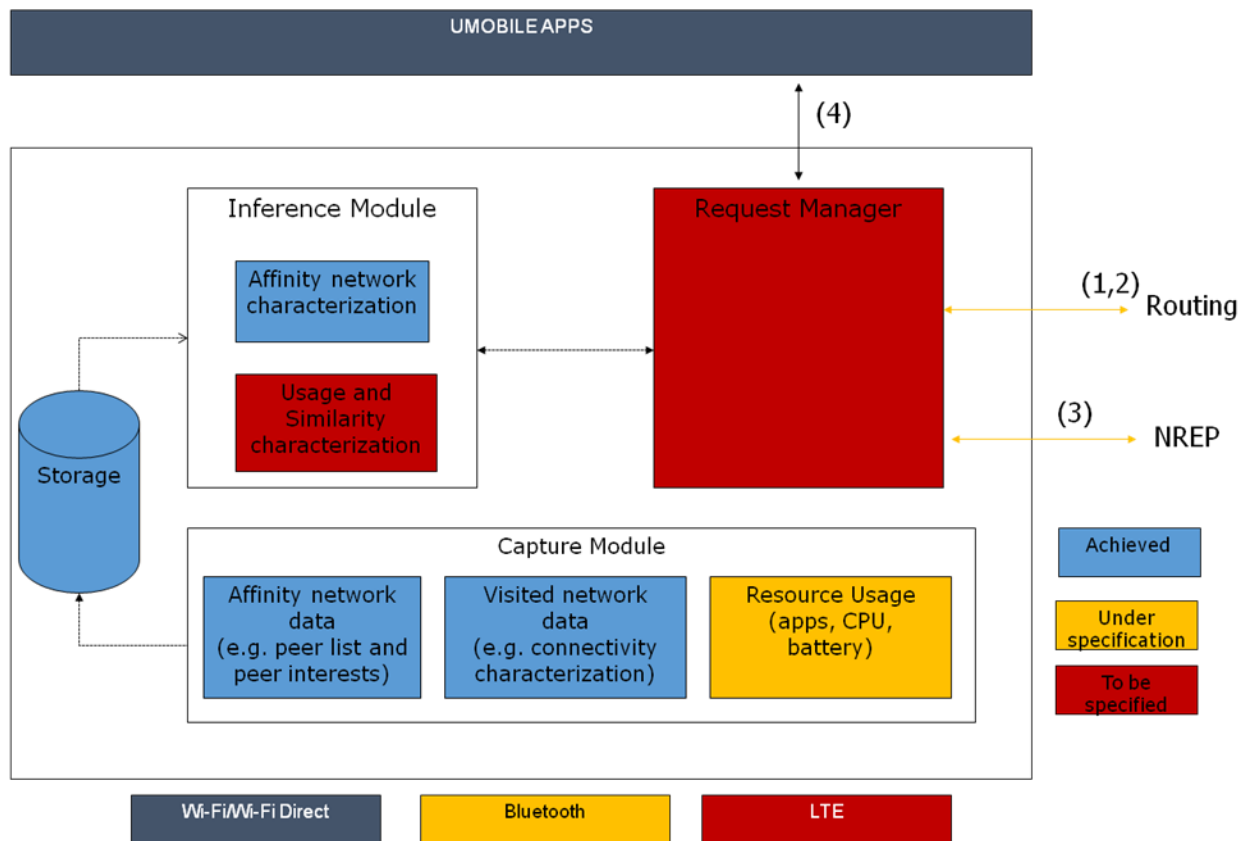

FIGURE 16 - UMOBILE CONTEXTUAL INFORMATION MODULE

Such “smart” captured data (in contrast to raw data) is then made available to a contextualization and behaviour inference module as well as to the routing/data sharing module. The data is only stored on the end-user device so the UMOBILE system obeys to the most recent EU rules concerning data privacy.

The contextualization and behaviour inference module then integrates specific models. For instance, a UMOBILE mobile device may present a roaming preferences model, where the intent is to consider personal preferences in terms of visited wireless networks. Or, it may contain a model that relates with the need to share data opportunistically based on frequency or volume of wireless contacts. These models are defined by the user, based on specific parameters. The identified user’s context is then used, together with the collected sensing data, to infer patterns of user behaviour.

The inference process, currently centralized, may be distributed among personal devices or may also include cloud computing entities, depending on the amount of data to be analysed, the required learning algorithms, as well as the delay tolerance and privacy levels of applications. Similar distribution of computational effort may be needed to adjust contextualization modelling, by considering quantifiable social parameters, and by adjusting them to the roaming dynamics that can characterize user’s behaviour with an

adequate level of assurance. Some aspects that are considered in the notion of context are:

- Social trust circles. These correspond to networks of devices owned and carried by users that share affinities, wishes, or interests. Trust circle computation assist in collective inference, derived not only from physical proximity, as well as from social proximity. Examples of trust circles are groups of friends; familiar strangers interested in a specific event.
- Social roaming footprint. The footprint that both individual and collective users exhibit when roaming around. Derived from wireless connectivity, it incorporates aspects such as duration of visits; common local places and paths.
- Personalized recommendations. Recommendations are filtered by the devices based on the personal and individual affinities of each user.

The indicators that the contextual plane can offer can be categorized into two main sets: i) affinity network characterization data (network context); ii) usage and similarity characterization data (usage context).

#### 4.3.1 Usage context

Usage characterization information is based on the internal device usage over time and space and is a measure on a node's capability and availability, at a specific instant in time, to carry data. For instance, we may consider indicators such as the preferred visited network and/or location of the device to exploit similarity between devices; type (category) of preferred application (e.g. most used over time window T); time spent per application category (e.g. per day).. The contextualization and behaviour inference module then integrates specific models. For instance, a UMOBILE mobile device may present a roaming preferences model, where the intent is to consider personal preferences in terms of visited wireless networks. Or, it may contain a model that relates with the need to share data opportunistically based on frequency or volume of wireless contacts. These models are defined by the user, based on specific parameters. The identified user's context is then used, together with the collected sensing data, to infer patterns of user behaviour.

#### 4.3.2 Network context

Through their mobile devices, users are presented with a multitude of opportunities to access information available in their networking vicinity in the form of opportunistically cached, pre-fetched/downloaded or locally generated content and/or services/applications providing static or dynamically generated content. Depending on the networking environment, information can reside at a wide range of accessible



network locations and application level user dynamics, as well as any explicit differentiation of accessible services and/or content, contribute to the expectation of information diversity in these locations. In turn, awareness of the availability (or expectancy) of information in the networking environment can lead to connectivity decisions that reflect user interests, thus facilitating or even enabling the otherwise impossible access to the desired information and creating or removing the logical faces in the NDN plane depending on the connectivity situation of the end-user.

Affinity network characterization information is based on time and spatial correlation data and is a measure on how global a node is (ranking). For instance, we consider aspects such as inter-contact times towards peers, but also consider categories of social interests (defined by applications or by the user, e.g., Ana likes World Music) for each peer; peer resource status (e.g., battery level, or expected time until battery drains; CPU status; storage status, etc); average, maximum, minimum connectivity duration for a specific time window T; inter-contact duration information; average node degree and its variation over time and space; cluster distance; visited places, etc.

#### 4.4 INRPP - Flow control

Given the dynamic nature of the considered use-cases, UMOBILE does not rely on the existence of end-to-end flows between communicating parties. Thus, the concept of flowlets is rather interesting, to provide applications with different quality of service mechanisms to allow satisfactory levels for the content being exchanged.

This functional block oversees how flowlets are started between the involved entities as to allow better, QoS-based data exchange and provide special support to in-network caching. It may provide QoS on-demand, by understanding the needs for QoS and making sure the content reaches its recipients respecting the desired QoS levels as much as possible.

However, we consider flow control out of the scope of this deliverable, and we detail the flow control for UMOBILE in D4.1 and D4.2, with a detailed specification of the proposed rate-regulation scheme.

#### 4.5 Service migration platform

As briefly explained in Section 3, the service migration platform is an application level QoS mechanisms meant to help service providers meet the QoS requirements imposed on the services under his responsibility. It accounts for the deployment of services of different classes: premium, best-effort, less-than-best-effort.



The service migration platform is based on the assumption that services can be packed as small (lightweight) executable images that can be seamlessly transferred through the network as close as possible to where the end-users are (edge of the network) and instantiated as self-contained virtual machines when needed. Regarding specific technologies, we use Docker to create the service images and instantiate them. At network level, we use the abstractions offered by the ICN paradigm such as name based routing/forwarding strategy and in-network caching. A salient feature of the service migration platform is that we use virtual machines that are identifiable by semantic names that can help end-users to customise their request, for example, a request issued to request a service can include the current location of the user so that the service deployed in response is context aware.

Service migration can help to deliver services with the expected QoS to the end users. For example, it can provide local availability of services where Internet connectivity is intermittent, temporarily impaired or unavailable. Adverse network conditions is relevant because, as mentioned in D2.1 (use case scenarios), UMOBILE needs to support various challenged scenarios such as areas impacted by disaster events, rural/remote areas with poor or no connectivity or networks with limited backhaul capacity.

The facilities provided by lightweight virtualization make the deployment of service instance transparent to the end-users in the sense that they do not need to know the location of the service replicas that are responding to their requests.

At implementation level, the service migration platform consists of three main modules that we will discuss next, namely, service manager, monitoring and service repository. These modules can be configured to operate in two modes: reactive and proactive.

### Reactive service migration

Reactive service migration is a reactive technique that service providers can use to meet QoS requirements imposed on services. It is used at service delivery time. The central idea is to react to the variations (between “vigorously running” and “showing signs of exhaustion”) in the status of the resources (computers and containers involved in the execution of service images) so that additional resources are allocated to ensure that QoS requirements are satisfied. This mechanism relies on QoS related metrics provided by the Monitoring Manager. In this order, additional replicas of containers are deployed when the current ones show signs of exhaustion.

To clarify the idea let us examine a specific example. Imagine that the Service Provider agrees to deploy a busybox web service under the following QoS requirements:

- **Requirement1:** *The service shall provide a response time no larger than 500 ms.*



- **Requirement2:** *The service provider shall be able to handle at least 700 concurrent users.*
- **Requirement2:** *The service shall be classed as premium service.*

To comply with its obligations, the Service Provider needs to know how many concurrent users a single instance of busybox service can handle with a response time below 500 ms. On this basis he can deploy as many instances as necessary to comply with Requirement1 and Requirement2 of his premium service. One alternative is to deploy additional instances gradually in response to signals of exhaustion sent by the running instances. Alternatively, to be free from the burden of listening for exhaustion signals and reacting, the service provider might opt to deploy all the instances needed to serve 700 concurrent users simultaneously and distribute the load evenly from the very beginning. This example is elaborated in deliverable D4.4 where we also show how one can conduct laboratory experiments to determine how many concurrent users an instance of a busybox service can handle.

### **Proactive service migration (pre-fetching)**

Proactive service migration (service pre-fetching) is a proactive technique that service providers can use to deploy services. The central idea is to use statistical knowledge and experience about the usage of services to transfer service images at convenient times (for example, at midnights or weekends) before the service is actually requested by end-users. Once the image is in place and ready for execution, it can be instantiated immediately when needed. This technique can be used to meet stringent deployment time (for example, of the order of a few seconds) imposed by premium services.

Service pre-fetching can prove beneficial in emergency situations that can be anticipated so that the images are transferred to the area before the undesirable event strikes and impacts the communication links.

Let us take an emergency scenario as an example to explain the operation of proactive service migration. Imagine that the service provider agrees to deploy emergency services in the event of disaster situations that might impact the communication infrastructure. Specifically, the service provider is committed to the following requirements:

- **Requirement1:** Emergency services Sa, and Sb are premium services and shall be available with 60 sec after being requested by end-users regardless of network conditions.
- **Requirement2:** Service Sc is a best-effort service and shall be in operation as soon as possible after being requested by end users.





Let us imagine that an undesirable event strikes and levels the communication infrastructure as shown in Figure 17. In the figure, the two disaster zones have suffered a network partition, and consequently, are disconnected from the UMOBILE Network. The UMOBILE Network is the main network and hosts a Service Manager and Service Repository. Also, imagine that Sa, Sb and Sc are cached in HS1, HS2 and HS3, respectively. The airplane shown in the figure is an Unmanned Aerial Vehicle (UAV) under the control of the service provider. In response to the situation, the UAV is instructed to repeatedly fly the distance between the main network and disaster zones. It is equipped with wireless communication facilities and storage that can be used for data muling, in particular, it can carry Interest request and data.

Imagine that the service manager receives through the UAV, an Interest request to deploy Sa in HS4, Sb in HS5 and Sc in both HS4 and HS5. To deploy the services, the service provider can rely on the storage facilities of the UAV to upload images of Sa, Sb and Sc (from HS1, HS2 and HS3, respectively) and deploy them as mentioned before. The drawback of this approach is that, due to the latency that the UAV inevitably introduces, there is a high risk of violating the availability requirement (Requirement1) imposed on the premium services Sa and Sb. A better alternative is to use a pre-fetching mechanism to pre-fetch the images of services (from HS1, HS2 and HS3, respectively) place them where they are likely to be needed and instantiate them immediately when requested. Service Sc deserves further explanation. Sc is only a best-effort service without stringent availability requirements. Because of this, the service provider is likely to prioritise the transfer of the images of Sa and Sb and care about the image of Sc only when the images of Sa and Sb are placed in HS4 and HS5 respectively and ready for instantiation. A similar example is elaborated in deliverable D4.4 where we also show how the pre-fetching can collaborate with INRPP to prioritise the deployment of premium services over best—effort services.



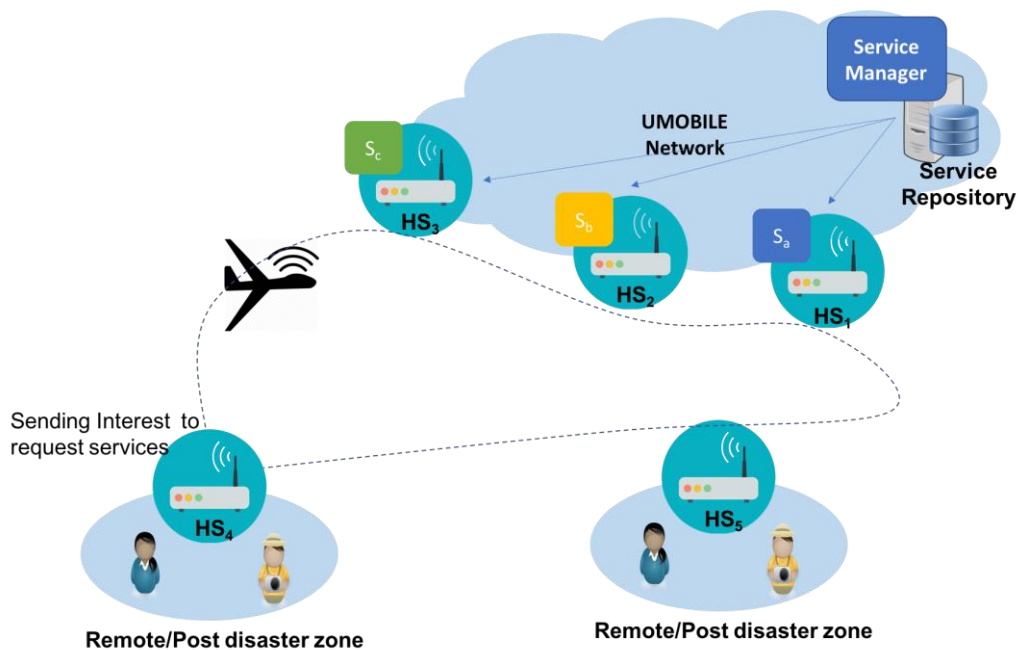

FIGURE 17 - Service-prefetching in emergency scenarios

We will explain in the following the multiple modules that the service migration function requires.

#### 4.5.1 Service manager

The Service Manager is the top-most module in the software hierarchy. At the disposition of the Service Manager is the Monitoring Manager, Service Repository and Decision Engine modules. The responsibility of the Service Manager is to coordinate the operation of its ancillary modules to ensure that services are deployed to meet the QoS requirements associated to them. The QoS requirements are provided by the owner of the services as deployment descriptors with QoS constraints (e.g., availability, maximum tolerate response time). Similarly, the monitored metrics are provided by a monitoring component.

#### 4.5.2 Monitoring Manager

The Monitoring Manager component is responsible for collecting QoS related metrics of the resources (for example, computers and containers) involved in the execution of the instances of the services. Typical examples of QoS related parameters are the number of users requesting a given service, load inflicted on existing replicas, performance of replicas, resources of the computer executing the replicas (memory, CPU, disk), network traffic, latency, and so on. The Monitoring Manager is supported by a set of monitors deployed in each hotspot to collect local metrics about the status of hot computer used to realize the hotspot and container currently running.

### 4.5.3 Decision engine

The decision engine is a software component instrumented with the necessary logics to i) collect monitored metrics from the Monitoring Manager about parameters that impact the QoS and ii) run algorithms to determine when and where a service should be deployed and iii) notify its decision to the Service Manager. Upon receiving a notification the Service Manager sends the image of the service to the Service execution.

### 4.5.4 Service repository

This module is responsible for holding images of services along with specifications that describe the features of the services and the QoS parameters that the service is expected to meet. Example of features are the class of the service (premium, best-effort, less-than-best effort) image size, number of users supported, etc. Examples of QoS parameters are response time, deployment time, availability, etc.

### 4.5.5 Service execution

The Service Execution is responsible for storing and executing services for the benefit of the end users. Conceptually, it can be implemented as computer with storage and processing facilities, such a Raspberry Pi. The Service Execution is capable and willing to receive compressed images of services from the Service Manager, uncompress, execute them and grant access to end users.

## 4.6 Connectivity manager

We propose that UMOBILE must enable *information-centric connectivity*, using a new module called Connectivity Manager, aimed at discovering the networks enabling and facilitating access to the desired information. In essence, information-awareness is introduced at the link layer, supporting connectivity decisions per wireless network interface. This way, it is expected to enhance user experience as information-centric connectivity decisions bring the user closer to the desired information, reducing latencies, along with network traffic.

In order to provide information-centric connectivity several options are available for WiFi interfaces. The first one is the Generic Advertisement Service (GAS) of IEEE 802.11u [40], which specifies a frame format and exchange process. The recently announced WiFi Neighbour Awareness Networking (NAN) protocol [41] also further supports a low energy consumption device discovery mechanism enhanced with publish/subscribe primitives that can serve the same purpose.

Information availability is further expected to improve when a connectivity decision either leads to the desired information or not *e.g.*, accessing photos in the aforementioned



example. Note that in this context, these benefits come without the currently imposed need to search for information upon the time and energy consuming network association process. This comes in sharp contrast to a substantial body of work on service discovery, which, in most cases, assumes the establishment of connectivity between participating devices, before any service discovery protocol is employed (*e.g.*, Jini, UPnP).



## 5 UMOBILE platform WP planning

The UMOBILE services previously specified, as extensions of NDN to provide opportunistic and social communications, are going to be developed in different tasks of the UMOBILE project. These tasks are not all of them part of the WP3 -System and node architecture Development-, on which the UMOBILE platform architecture has been designed. Some of the tasks are part of the WP4 -Services enablement- as well. In the next figure, it can be identified what parts of the UMOBILE platform are developed in the WP3 and what parts of the platform are developed in WP4, and in which tasks.

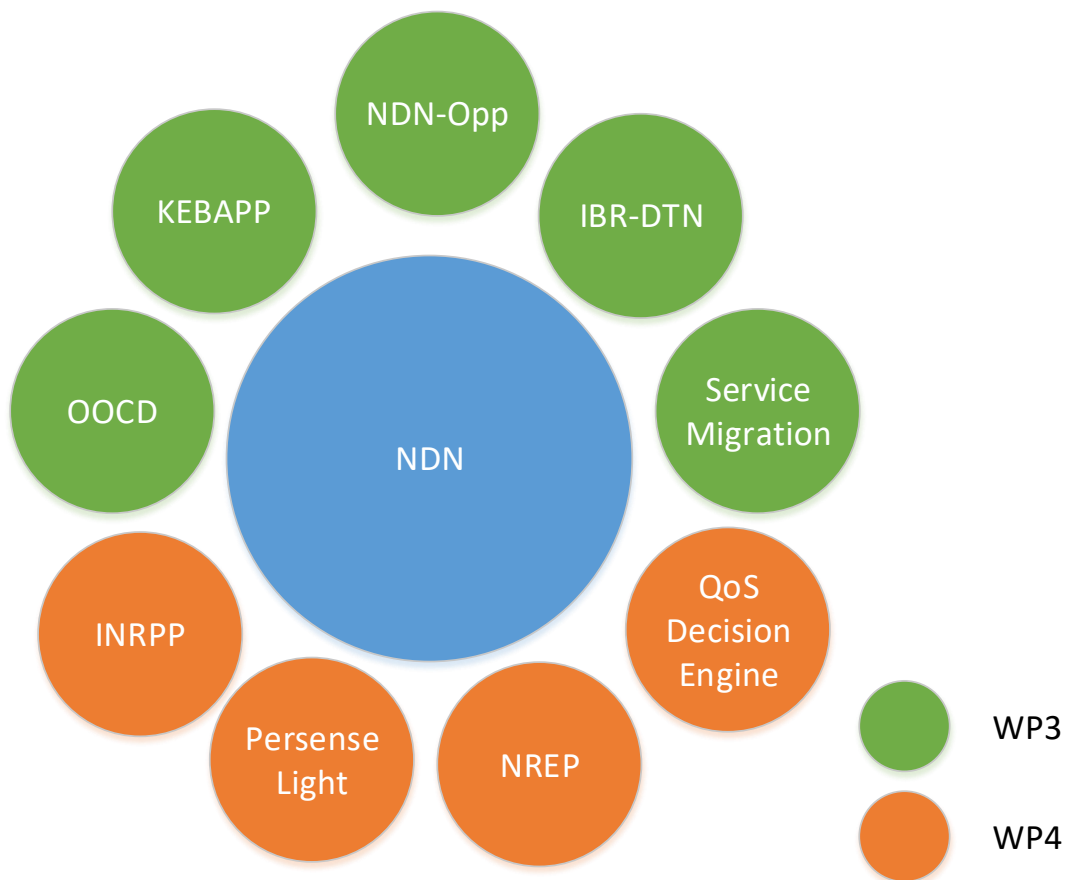

FIGURE 18 – WP PLANNING

- NDN-Opp: WP3 – Task3.1: Design of a NDN compatible android framework able of making use of a wide variety of opportunistic routing algorithms, being dLife/Scorp the first example; Task 3.3: Development of a novel opportunistic routing algorithm based on social interaction among wireless nodes. (D3.1, D3.2),
- IBR-DTN: WP3 – Task 3.1: DTN overlay design and convergence layers for underlying protocols (D3.1, D3.2).

- KEBAPP: WP3 – Task 3.2: Providing service-abstraction to applications through content-centric approaches (D3.1, D3.2).
- O OCD: WP3 – Task 3.2: Providing service-abstraction to applications through content-centric approaches (D3.1, D3.2).
- Service migration platform: WP3-Task3.2: Providing the mechanisms for Dockerizing and migrating services. (D3.1, D3.2).
- INRPP: WP4 – Task 4.1: Providing different levels of QoS and flow control. (D4.1, D4.2).
- PerSense Light: WP4 – Task 4.2: Data collection and contextual inference (D4.5).
- NREP: WP4 – Task 4.3: Name-Based Replication Priorities (D4.3).
- QoS Decision Engine: WP4-Task 4.1: Providing the algorithms to determine what services to migrate, when and where (D4.4).



## 6 Conclusion

In this document, we defined a high-level view of the UMOBILE architecture, revising the initial high-level definition reported in deliverable D3.3. The proposed architecture aims to deal with the different areas of action defined in the D2.1 document of the UMOBILE project. It integrates the DTN and ICN paradigms into a unified architecture that is able to handle the scenarios envisioned in D2.1, providing an architecture compatible with opportunistic communications, based on NDN, and capable of pushing services to the edge of the network to prevent issues caused by intermittent communications. The high-level design discussed in this document, is complemented by a low-level design documented in deliverables D3.1 and D3.2.



## References

- [1] V. Cerf, S. Burleigh, A. Hooke, L. Torgerson, R. Durst, K. Scott, K. Fall, H. Weiss, *Delay-Tolerant Networking Architecture*, IETF RFC 4838, April 2007.
- [2] George Xylomenos, Christopher N. Ververidis, Vasilios A. Siris, Nikos Fotiou, Christos Tsilopoulos, Xenofon Vasilakos, Konstantinos V. Katsaros, and George C. Polyzos, "A Survey of Information-Centric Networking Research," *IEEE Communications Surveys Tutorials*, vol. 16, no. 2, 2014.
- [3] Sotiris Diamantopoulos, Christos-Alexandros Sarros, Dimitris Vardalis, Ioannis Komnios, Vassilis Tsaoussidis, Ioannis Psaras, Sergi Rene, Adisorn Lertsinsrubtavee, Carlos Molina-Jimenez, Paulo Mendes, Waldir Moreira, Iñigo Sedano, Rute Sofia, "D3.1 UMOBILE architecture report - initial version," UMOBILE Project, 2016.
- [4] Sotiris Diamantopoulos, Christos-Alexandros Sarros, Dimitris Vardalis, Ioannis Komnios, Vassilis Tsaoussidis, Ioannis Psaras, Sergi Rene, Adisorn Lertsinsrubtavee, Carlos Molina-Jimenez, Paulo Mendes, Susana Sanchez Perez, Rute Sofia, "D3.2 UMOBILE architecture report - final version," UMOBILE Project, 2017.
- [5] Paulo Mendes, Sotiris Diamantopoulos, Nikos Bezirgiannidis, Ioannis Komnios, Ioannis Psaras, Sergi Rene, Adisorn Lertsinsrubtavee, Arjuna Sathiaselan, Susana Perez Sanchez, Francisco Almeida, Francesco Amorosa, Giammichele Russi, Angela d'Angelo, Alberto, "D2.1 - End-User Requirements Report," UMOBILE project, Grant 645124, June 2015.
- [6] Paulo Mendes, Sotiris Diamantopoulos, Nikos Bezirgiannidis, Ioannis Komnios, Ioannis Psaras, Sergi Rene, Adisorn Lertsinsrubtavee, Arjuna Sathiaselan, Susana Perez Sanchez, Francisco Almeida, Francesco Amorosa, Giammichele Russi, Angela d'Angelo, Alberto, "D2.2 - System and Network Requirements Specification -initial version-," UMOBILE project, March 2016.
- [7] Paulo Mendes, Sotiris Diamantopoulos, Nikos Bezirgiannidis, Ioannis Komnios, Ioannis Psaras, Sergi Rene, Adisorn Lertsinsrubtavee, Arjuna Sathiaselan, Susana Perez Sanchez, Francisco Almeida, Francesco Amorosa, Giammichele Russi, Angela d'Angelo, Alberto, "D2.3 System and Network Requirements Specification -final version-," UMOBILE Project, July 2017.
- [8] Sergi Rene, Ioannis Psaras, Sotiris Diamantopoulos, Ioannis Komnios, Vassilis Tsaoussidis, Adisorn Lertsinsrubtavee, Arjuna Sathiaselan, Carlos Molina-Jimenez, "D4.1 Flowlet Congestion Control – Initial Report," UMOBILE Project, 2016.
- [9] Sergi Rene, Ioannis Psaras, Sotiris Diamantopoulos, Ioannis Komnios, Vassilis Tsaoussidis, Adisorn Lertsinsrubtavee, Arjuna Sathiaselan, Carlos Molina-Jimenez, "D4.2 Flowlet Congestion Control – Final Report," UMOBILE Project, 2017.





- [10] Sergi Rene, Ioannis Psaras and Rute Sofia, "D4.3 Name-based Replication Priorities," UMOBILE Project, 2017.
- [11] Carlos Molina-Jimenez, Adisorn Lertsinsruttavee, Arjuna Sathiseelan, Sergi Rene, Ioannis Psaras, Sotiris Diamantopoulos, Ioannis Komnios, Vassilis Tsaoussidis, "D4.4 Set of QoS interfaces and algorithms," UMOBILE Project, 2017.
- [12] Rute Sofia, "D4.5 Report on data collection and inference models," UMOBILE Project, 2016.
- [13] K. Scott and S. Burleigh, *Bundle Protocol Specification. RFC 5050 (Experimental)*, 2007.
- [14] D. Kutscher, S. Eum, K. Pentikousis, I. Psaras, D. Corujo, D. Saucez, T. Schmidt, M. Waehlich ..., *Information-Centric Networking (ICN) Research Challenges*, RFC7927 (DOI: 10.17487/RFC7927), July 2016.
- [15] G. Tyson, J. Bigham, and E. Bodanese, "Towards an information-centric delay-tolerant network," in *IEEE INFOCOM Workshop on Emerging Design Choices in Name-Oriented Networking (NOMEN)*, 2013.
- [16] Cisco White Paper, "Fog Computing and the Internet of Things: Extend the Cloud to Where the Things," [Online]. Available: [https://www.cisco.com/c/dam/en\\_us/solutions/trends/iot/docs/computing-overview.pdf](https://www.cisco.com/c/dam/en_us/solutions/trends/iot/docs/computing-overview.pdf). [Accessed 2016].
- [17] Van Jacobson, Diana K. Smetters, Nicholas H. Briggs, Michael F. Plass, Paul Stewart, James D. Thornton, Rebecca L. Braynard, "VoCCN: voice-over content-centric networks," in *International workshop on re-architecting the internet*, Rome, 2009.
- [18] G. Xylomenos, X. Vasilakos, C. Tsilopoulos, V. A. Siris and G. C. Polyzos, "Caching and mobility support in a publish-subscribe internet architecture," *IEEE Communications Magazine*, vol. 50, no. 7, pp. 52-58, 2012.
- [19] Teemu Koponen, Mohit Chawla, Byung-Gon Chun, Andrey Ermolinskiy, Kye Hyun Kim, Scott Shenker, and Ion Stoica, "A data-oriented (and beyond) network architecture," in *SIGCOMM*, August 2007.
- [20] D. Kutscher, S. Farrell, and E. Davies, *Internet-Draft. The NetInf Protocol. draft-kutscher-icnrg-netinf-proto*, Internet Engineering Task Force, 2012.
- [21] W. K. Chai et al, "Curling: Content-ubiquitous resolution and delivery infrastructure for next-generation services," *IEEE Communications Magazine*, vol. 49, no. 3, pp. 112-120, 2011.
- [22] *Information-Centric Networking (icnrg)*, <https://datatracker.ietf.org/rg/icnrg/charter/>.
- [23] Ioannis Psaras, Richard G. Clegg, Raul Landa, Wei Koong Chai, and George Pavlou, "Modelling and evaluation of CCN-caching trees," in *10th international IFIP TC 6 conference on Networking (NETWORKING'11)*, Valencia, 2011.



- [24] Ioannis Psaras, Wei Koong Chai and George Pavlou, "In-Network Cache Management and Resource Allocation for Information-Centric Networks," *IEEE Transactions on Parallel and Distributed Systems*, vol. 25, no. 11, pp. pp. 2920-2931, Nov. 2014.
- [25] Wei Koong Chai, Diliang He, Ioannis Psaras, and George Pavlou, "Cache "less for more" in information-centric networks," in *11th international IFIP TC 6 conference on Networking (NETWORKING'12)*, Berlin, 2012.
- [26] Cheng Yi, Jerald Abraham, Alexander Afanasyev, Lan Wang, Beichuan Zhang, and Lixia Zhang, "On the role of routing in named data networking," in *1st ACM Conference on Information-Centric Networking (ACM-ICN '14)*, New York, 2014.
- [27] Vassilis Sourlas, Leandros Tassioulas, Ioannis Psaras and George Pavlou, "Information resilience through user-assisted caching in disruptive Content-Centric Networks," in *International IFIP TC 6 Conference on Networking (NETWORKING'15)*, Toulouse, 2015.
- [28] Gareth Tyson, Nishanth Sastry, Ivica Rimac, Ruben Cuevas, and Andreas Mauthe, "A survey of mobility in information-centric networks: challenges and research directions," in *1st ACM workshop on Emerging Name-Oriented Mobile Networking Design - Architecture, Algorithms, and Applications (NoM '12)*, New York, 2012.
- [29] Y. T. Yu, J. Joy, R. Fan, Y. Lu, M. Gerla and M. Y. Sanadidi, "DT-ICAN: A Disruption-Tolerant Information-centric Ad-Hoc Network," in *IEEE Military Communications Conference*, Baltimore, 2014.
- [30] M. Amadeo, C. Campolo, A. Iera and A. Molinaro, "Named data networking for IoT: An architectural perspective," in *European Conference on Networks and Communications (EuCNC)*, Bologna, 2014.
- [31] Ioannis Psaras, Lorenzo Saino, Mayutan Arumathurai, K. K. Ramakrishnan and George Pavlou, " Name-Based Replication Priorities in Disaster Cases," in *2nd Workshop on Name Oriented Mobility (NOM 2014) in conjunction with the IEEE INFOCOM*, Toronto, 2014.
- [32] V. Jacobson, D. K. Smetters, J. D. Thornton, M. F. Plass, N.H. Briggs, R.L. Braynard, "Networking Named Content," in *CoNEXT*, Rome, December 2009.
- [33] Christos Tsilopoulos and George Xylomenos, "Supporting Diverse Traffic Types in Information Centric Networks," in *ACM SIGCOMM workshop on Information-centric networking*, Toronto, 2011.
- [34] "ccnd 0.7.2 forwarding strategy," [Online]. Available: <http://redmine.named-data.net/projects/nfd/wiki/CcndStrategy>. [Accessed 2016].
- [35] A. Tagami et al, *Name-based push/pull message dissemination for disaster message board*, Rome: IEEE International Symposium on Local and Metropolitan Area Networks (LANMAN), 2016, pp. pp. 1-6..



- [36] Sergi Rene, Ioannis Psaras, Ioannis Komnios, Sotiris Diamantopoulos, Vassilis Tsaoussidis, Adisorn Lertsinsrubtavee, Paulo Mendes, Waldir Moreira, Luis Amaral Lopes, Iñigo Sedano, Susana Sanchez Perez, Rute Sofia, "D3.3 UMOBILE ICN layer abstraction initial specification," UMOBILE Project, 2016.
- [37] Luis Amaral Lopes, Rute C. Sofia, Paulo Mendes, Waldir Moreira, "Oi! - Opportunistic Data Transmission Based on Wi-Fi Direct," in *IEEE INFOCOM*, San Francisco, 2016.
- [38] Waldir Moreira, Paulo Mendes, Susana Sargento, "Opportunistic Routing based on daily routines," in *IEEE WoWMoM workshop on autonomic and opportunistic communications*, San Francisco, 2012.
- [39] Waldir Moreira, Paulo Mendes, Susana Sargento, "Social-aware Opportunistic Routing Protocol based on User's Interactions and Interests," in *AdhocNets*, Barcelona, 2013.
- [40] IEEE Standard 802.11u, *IEEE Standard for Information Technology-Telecommunications and information exchange between systems-Local and Metropolitan networks-specific requirements-Part II: Wireless LAN Medium Access Control (MAC) and Physical Layer (PHY) specifications*.
- [41] D. Camps-Mur et al, "Enabling always on service discovery: Wifi neighbor awareness networking," *IEEE Wireless Communications*, 2015.
- [42] Upeka De Silva, Adisorn Lertsinsrubtavee, Arjuna Sathiaseelan, Carlos Molina-Jimenez, and Kanchana Kanchanasut, "Implementation and evaluation of an information centric-based smart lighting controller," in *12th Asian Internet Engineering Conference (AINTER'16)*, Bangkok, 2016.
- [43] Upeka De Silva, Adisorn Lertsinsrubtavee, Arjuna Sathiaseelan, and Kanchana Kanchanasut, "Named Data Networking Based Smart Home Lighting," in *ACM SIGCOMM Conference (SIGCOMM '16)*, Florianópolis, 2016.

